

ACE II GPS™

System Designer Reference Manual

Part Number: 39538-00

Firmware: 7.80

Date: June 1999

Trimble Navigation Limited
Software and Component Technologies
645 North Mary Avenue
Post Office Box 3642
Sunnyvale, CA 94088-3642
U.S.A.

+1-800-827-8000 in North America
+1-408-481-8000 International
FAX: +1-408-730-2082

U.S. Technical Assistance and Repair

+1-800--SOS-4-TAC in North America
+1-408-481-6940 International
FAX: +1-408-481-6020

European Technical Assistance and Repair

+44-1256-1622-858-421

Copyrights

© 1999 Trimble Navigation Limited. All rights reserved. No part of this manual may be copied, photocopied, reproduced, translated, or reduced to any electronic medium or machine-readable form without prior written consent from Trimble Navigation Limited.

Printed in the United States of America. Printed on recycled paper.

Revision Notice

This is the second release of the ACE II GPS™ System Designer Reference Manual, Part Number 36916-01, March 1999.

Trademarks

ACE II GPS, SVeeSix, SVeeSix-CM3, Lassen-SK8, Acutis, Acutime, AcutimeII, and TSIP are trademarks of Trimble Navigation Limited. IBM is a registered trademark of International Business Machines, Inc. MS-DOS and Windows is a trademark of Microsoft Corporation. Intel is a trademark of Intel Corporation. All other brand names are trademarks of their respective holders.

Disclaimer of Warranty

EXCEPT AS INDICATED IN "LIMITED WARRANTY" HEREIN, TRIMBLE HARDWARE, SOFTWARE, FIRMWARE AND DOCUMENTATION IS PROVIDED "AS IS" AND WITHOUT EXPRESS OR LIMITED WARRANTY OF ANY KIND BY EITHER TRIMBLE OR ANYONE WHO HAS BEEN INVOLVED IN ITS CREATION, PRODUCTION, OR DISTRIBUTION INCLUDING BUT NOT LIMITED TO THE IMPLIED WARRANTIES OF MERCHANTABILITY AND FITNESS FOR A PARTICULAR PURPOSE. THE ENTIRE RISK, AS TO THE QUALITY AND PERFORMANCE OF THE TRIMBLE HARDWARE, SOFTWARE, FIRMWARE AND DOCUMENTATION, IS WITH YOU. SOME STATES DO NOT ALLOW THE EXCLUSION OF IMPLIED WARRANTIES, SO THE ABOVE EXCLUSION MAY NOT APPLY TO YOU.

Limitation of Liability

IN NO EVENT WILL TRIMBLE OR ANY PERSON INVOLVED IN THE CREATION, PRODUCTION, OR DISTRIBUTION OF THE TRIMBLE PRODUCT BE LIABLE TO YOU ON ACCOUNT OF ANY CLAIM FOR ANY DAMAGES, INCLUDING ANY LOST PROFITS, LOST SAVINGS, OR OTHER SPECIAL, INCIDENTAL, CONSEQUENTIAL, OR EXEMPLARY DAMAGES, INCLUDING BUT NOT LIMITED TO ANY DAMAGES ASSESSED AGAINST OR PAID BY YOU TO ANY THIRD PARTY, ARISING OUT OF THE USE, LIABILITY TO USE, QUALITY OR PERFORMANCE OF SUCH TRIMBLE PRODUCT INCLUDING HARDWARE, SOFTWARE, FIRMWARE, AND DOCUMENTATION, EVEN IF TRIMBLE OR ANY SUCH PERSON OR ENTITY HAS BEEN ADVISED OF THE POSSIBILITY OF DAMAGES, OR FOR ANY CLAIM BY ANY OTHER PARTY. SOME STATES DO NOT ALLOW THE LIMITATION OR EXCLUSION OF LIABILITY FOR INCIDENTAL OR CONSEQUENTIAL DAMAGES SO, THE ABOVE LIMITATIONS MAY NOT APPLY TO YOU.

Software and Firmware Limited Warranty

Trimble warrants that Software and Firmware products will substantially conform to the published specifications provided it is used with the Trimble products, computer products, and operating system for which it was designed. For a period of ninety (90) days, commencing thirty (30) days after shipment from Trimble, Trimble also warrants that the magnetic media on which Software and Firmware are distributed and the documentation are free from defects in materials and workmanship. During the ninety (90) day warranty period, Trimble will replace defective media or documentation, or correct substantial program errors at no charge. If Trimble is unable to replace defective media or documentation, or correct program errors, Trimble will refund the price paid for The Software. These are your sole remedies for any breach in warranty.

Hardware Limited Warranty

Trimble Navigation Limited products are warranted against defects in material and workmanship for a period of one year. The warranty period shall commence thirty (30) days after shipment from Trimble's factory. Warranty service will be provided at a designated Trimble Service Center. Trimble will at its option either repair or replace products that prove to be defective. The Customer shall pay all shipping charges for products returned to Trimble for warranty service. Trimble shall pay all shipping charges for the return of products to the Customer.

This warranty shall not apply to defects resulting from one or more of the following:

- Improper or inadequate maintenance by the buyer
- Buyer-supplied software or interfacing
- Unauthorized modification or misuse
- Operation outside of the environmental specifications of the product
- Improper installation, where applicable
- Lightning or other electrical discharge
- Fresh or salt water immersion or spray
- Normal wear and tear on consumable parts (for example, batteries)

No other warranty is expressed or implied. Trimble Navigation Limited specifically disclaims the implied warranties of fitness for a particular purpose and merchantability.

Table of Contents

Preface

Scope and Audience	xv
ACE II GPS Manual Organization	xvi
Technical Assistance	xvi
Email.	xvi
Worldwide Web	xvii
Internet FTP Address	xvii
FaxBack	xvii
Reader Comments	xvii
Document Conventions.	xviii
Notes, Tips, Cautions, and Warnings.	xviii

1 Starter Kit

1.1 ACE II GPS Overview	1-2
1.1.1 Interface Protocols	1-3
Port 1	1-3
Port 2	1-3
DGPS	1-3
1.1.2 Starter Kit Components	1-3
1.2 GPS Receiver Module	1-5
1.2.1 Starter Kit Serial Port Interface	1-7
1.3 Antenna.	1-8
1.4 Power	1-10
1.5 Hardware Setup.	1-11
1.6 Running the TSIPMonitor32 Interface Program	1-12

2 Hardware Integration

2.1 The ACE II GPS Receiver Module.	2-1
2.2 Interface Connector.	2-3
2.3 Power Requirement.	2-3
2.4 Serial Interface	2-4

2.5	Pulse Per Second	2-5
2.6	Mounting	2-5

3 Software Interface

3.1	Start-up	3-1
3.2	Software Tool Kits	3-2
3.3	Communicating with the ACE II GPS Module	3-2
3.4	Protocol Summary	3-3
3.4.1	TSIP Data Output	3-3
3.4.2	TAIP Data Output	3-4
3.4.3	NMEA 0183 Data Output	3-4
3.5	Timing Applications	3-5
3.5.1	Effect of GPS Week Number Roll-over (WNRO).	3-5
3.5.2	ACE II GPS/Palisade Family Firmware Version 7.xx Software Modifications	3-6
3.6	Differential GPS	3-6
3.7	Configuring the ACE II GPS Receiver Protocols	3-7
3.7.1	Re-configuring PORT1	3-7
3.7.2	Entering the Configuration	3-8
3.7.3	Saving the Configuration	3-10
3.7.4	Returning to the Factory Settings	3-10

4 Operation and Performance

4.1	GPS Satellite Message	4-1
4.2	Satellite Acquisition and Time to First Fix.	4-2
4.2.1	Cold-Start	4-2
4.2.2	Warm Start.	4-2
4.2.3	Garage Search Strategy	4-3
4.2.4	Hot Start	4-3
4.3	Satellite Mask Settings	4-3
4.3.1	Elevation Mask	4-4
4.3.2	SNR Mask	4-4
4.3.3	DOP Mask	4-4
4.3.4	PDOP Switch	4-5
4.4	Standard Operating Modes	4-5
4.4.1	Fix Modes	4-5
	2D Manual.	4-5
	3D Manual.	4-6
	2D/3D Automatic	4-6

4.5	Differential GPS Operating Modes	4-6
4.5.1	DGPS On	4-6
4.5.2	DGPS Off	4-6
4.5.3	DGPS Automatic	4-6
4.5.4	Differential GPS Operation	4-7
4.6	Position Accuracy	4-7
4.6.1	Selective Availability (SA)	4-7
4.6.2	Differential GPS (DGPS)	4-7
4.7	Coordinate Systems.	4-8
4.7.1	TSIP Coordinate Systems	4-8
4.7.2	NMEA 0183	4-9
4.7.3	TAIP	4-9
4.8	Performance Characteristics	4-9
4.8.1	Update Rate	4-9
4.8.2	Dynamic Limits	4-9
4.8.3	Re-Acquisition.	4-9
4.9	GPS Timing.	4-10
4.9.1	Serial Time Output	4-10
4.9.2	Timing Pulse Output (PPS)	4-11
4.10	System Architecture	4-11

A Trimble Standard Interface Protocol

A.1	Interface Scope	A-1
A.2	Automatic Output Packets	A-2
A.3	Customizing Receiver Operations	A-3
A.4	Automatic Position and Velocity Reports	A-3
A.5	Initialization Packets to Speed Start-up	A-4
A.6	Packets Output at Power-Up	A-4
A.7	Differential GPS Packets	A-5
A.8	Timing Packets	A-5
A.9	Satellite Data Packets.	A-5
A.10	Background Packets	A-6
A.11	Backwards Incompatibility of ACE II GPS Packets with Previous Versions of CM3 and SVEeSix	A-6
A.12	Recommended TSIP Packets	A-8
A.13	Command Packets Sent to the Receiver	A-10
A.14	Report Packets Sent by the GPS Receiver to the User	A-12
A.15	Key Setup Parameters	A-13

A.15.1	Packet BB	A-13
	Set Fix Mode	A-14
	Dynamics Code	A-15
	Elevation Mask	A-15
	Signal Level Mask	A-15
	DOP Mask and Switch	A-16
	Set DGPS Mode	A-16
A.16	Packet Structure	A-17
A.17	Packet Descriptions.	A-17
A.17.1	Report Packet 0x13 - Packet Received	A-17
A.17.2	Command Packet 0x1D - Clear Oscillator Offset	A-18
A.17.3	Command Packet 0x1E - Clear Battery Backup, then Reset	A-18
A.17.4	Command Packet 0x1F - Request Software Versions	A-18
A.17.5	Command Packet 0x20 - Request Almanac	A-18
A.17.6	Command Packet 0x21 - Request Current Time	A-19
A.17.7	Command Packet 0x22 - Position Fix Mode Select.	A-19
A.17.8	Command Packet 0x23 - Initial Position (XYZ Cartesian ECEF)	A-19
A.17.9	Command Packet 0x24 - Request GPS Receiver Position Fix Mode	A-20
A.17.10	Command Packet 0x25 - Initiate Soft Reset & Self Test	A-20
A.17.11	Command Packet 0x26 - Request Health	A-20
A.17.12	Command Packet 0x27 - Request Signal Levels	A-20
A.17.13	Command Packet 0x28 - Request GPS Systems Message	A-20
A.17.14	Command Packet 0x29 - Request Almanac Health Page	A-20
A.17.15	Command Packet 0x2A - Altitude for 2-D Mode	A-20
A.17.16	Command Packet 0x2B - Initial Position (Latitude, Longitude, Altitude)	A-21
A.17.17	Command Packet 0x2C - Set/Request Operating Parameters	A-22
A.17.18	Command Packet 0x2D - Request Oscillator Offset	A-23
A.17.19	Command Packet 0x2E - Set GPS Time	A-23
A.17.20	Command Packet 0x2F - Request UTC Parameters.	A-23
A.17.21	Command Packet 0x31 - Accurate Initial Position (XYZ Cartesian ECEF)	A-24
A.17.22	Command Packet 0x32 - Accurate Initial Position (Latitude, Longitude, Altitude)	A-24
A.17.23	Command Packet 0x35 - Set/Request I/O Options	A-25
A.17.24	Command Packet 0x37 - Request Status and Values of Last Position and Velocity	A-27
A.17.25	Command Packet 0x38 - Request/Load Satellite System Data	A-27
A.17.26	Command Packet 0x39 - Set/Request Satellite Disable or Ignore Health.	A-28
A.17.27	Command Packet 0x3A - Request Last Raw Measurement	A-29
A.17.28	Command Packet 0x3B - Request Current Status Of Satellite Ephemeris Data	A-30
A.17.29	Command Packet 0x3C - Request Current Satellite Tracking Status	A-30

A.17.30	Command / Report Packet 0x3D - Primary Port Configuration.	A-30
A.17.31	Report Packet 0x40 - Almanac Data Page.	A-32
A.17.32	Report Packet 0x41 - GPS Time.	A-33
A.17.33	Report Packet 0x42 - Single-Precision Position Fix, XYZ ECEF	A-34
A.17.34	Report Packet 0x43 - Velocity Fix, XYZ ECEF.	A-34
A.17.35	Report Packet 0x45 - Software Version Information	A-35
A.17.36	Report Packet 0x46 - Health of Receiver	A-35
A.17.37	Report Packet 0x47 - Signal Levels for all Satellites	A-36
A.17.38	Report Packet 0x48 - GPS System Message	A-37
A.17.39	Report Packet 0x49 - Almanac Health Page	A-37
A.17.40	Report Packet 0x4A - 20 Byte Format	A-37
A.17.41	Report Packet 0x4A - 9 Byte Format	A-38
	Reference Altitude.	A-38
	Altitude Flag.	A-38
A.17.42	Report Packet 0x4B - Machine/Code ID and Additional Status	A-39
A.17.43	Report Packet 0x4C - Report Operating Parameters	A-40
A.17.44	Report Packet 0x4D - Oscillator Offset	A-40
A.17.45	Report Packet 0x4E - Response to Set GPS Time.	A-40
A.17.46	Report Packet 0x4F - UTC parameters	A-41
A.17.47	Report Packet 0x55 - I/O Options	A-41
A.17.48	Report Packet 0x56 - Velocity Fix, East-North-Up (ENU)	A-43
A.17.49	Report Packet 0x57 - Information About Last Computed Fix	A-43
A.17.50	Report Packet 0x58 - Satellite System Data/Acknowledge from Receiver	A-44
A.17.51	Report Packet 0x59 - Status of Satellite Disable or Ignore Health	A-47
A.17.52	Report Packet 0x5A - Raw Measurement Data	A-48
A.17.53	Report Packet 0x5B - Satellite Ephemeris Status	A-50
A.17.54	Report Packet 0x5C - Satellite Tracking Status	A-51
A.17.55	Command Packet 0x60 - Type 1 Differential GPS Corrections.	A-52
A.17.56	Command Packet 0x61 - Set Differential GPS Corrections.	A-53
A.17.57	Command Packet 0x62 - Request/Set Differential Position Fix Mode	A-53
A.17.58	Command Packet 0x65 - Request Differential Correction Status	A-53
A.17.59	Report Packet 0x6D - All-In-View Satellite Selection	A-54
A.17.60	Command Packet 0x6E - Set or Request Synchronized Measurement Parameters	A-54
	Enable / Disable Synchronized Measurements	A-54
	Output Level.	A-54
A.17.61	Report Packet 0x6E — Synchronized Measurements.	A-55
A.17.62	Report Packet 0x6F, Subcode 1	A-56
A.17.63	Command Packet 0x70 - Filter Control	A-57

A.17.64	Report Packet 0x70	A-58
A.17.65	Command Packet 0x71 - Set/Request/Disable Position Filter	A-58
A.17.66	Report Packet 0x72 - Position Filter Parameters	A-59
A.17.67	Command Packet 0x73 - Set/Request/Disable Altitude Filter	A-60
A.17.68	Report Packet 0x74 - Altitude Filter Parameters	A-60
A.17.69	Command Packet 0x75	A-60
A.17.70	Report Packet 0x76	A-60
A.17.71	Command Packet 0x77 - Set/Request Maximum Age of Differential Corrections	A-61
A.17.72	Report Packet 0x78 - Maximum Age of Differential Corrections	A-61
A.17.73	Command Packet 0x7A	A-61
A.17.74	Report Packet 0x7B	A-62
A.17.75	Report Packet 0x82 - Differential Position Fix Mode.	A-63
A.17.76	Report Packet 0x83 - Double-Precision XYZ Position Fix and Bias Information	A-63
A.17.77	Report Packet 0x84 - Double-Precision LLA Position Fix and Bias Information	A-64
A.17.78	Report Packet 0x85 - Differential Corrections Status.	A-64
A.17.79	Packets 0x8E and 0x8F - Superpacket	A-65
A.17.80	Command Packet 0xBB - Navigation Configuration	A-65
A.17.81	Command Packet 0xBC - Protocol Configuration	A-66
A.18	TSIP Superpackets	A-68
A.18.1	Command Packet 0x8E-03 - Set / Request Auxiliary Configuration	A-68
A.18.2	Report Packet 0x8F-03 - Request Auxiliary Port Configuration	A-70
A.18.3	Command Packet 0x8E-15 - Set/Request Datum	A-70
A.18.4	Report Packet 0x8F-15 - Current Datum Values	A-71
A.18.5	Report Packet 0x8F-17 - UTM Single Precision Output	A-71
A.18.6	Report Packet 0x8F-18 - UTM Double Precision Output.	A-72
A.18.7	Command Packet 0x8E-19 - Enable / Disable UTM Output	A-73
A.18.8	Report Packet 0x8F-19 UTM Status	A-74
A.18.9	Command Packet 0x8E-20 - Request last fix with Extra Information	A-74
A.18.10	Report Packet 0x8F-20 - Last Fix with Extra Information (binary fixed point) A-74	
A.18.11	Command Packet 0x8E-26 - SEEPROM Storage.	A-77
A.18.12	Report Packet 0x8F-26 - SEEPROM Storage Status	A-77
A.18.13	Command Packet 0x8E-40 - TAIP Configuration.	A-77
A.18.14	Report Packet 0x8F-40 - TAIP Configuration	A-78
A.19	Datums	A-79

B TSIP Toolkit User's Guide

	32 bit Windows Applications	B-1
	DOS Programs and C Source Code	B-1
B.1	TSIPMonitor32	B-2
B.1.1	Delta Position	B-3
B.1.2	File Storage	B-3

C Trimble ASCII Interface Protocol (TAIP)

C.1	Message Format	C-2
C.1.1	Start of a New Message	C-2
C.1.2	Message Qualifier	C-2
C.1.3	Message Identifier	C-3
C.1.4	Data String	C-3
C.1.5	Vehicle ID	C-3
C.1.6	Checksum	C-3
C.1.7	Message Delimiter	C-3
C.2	Sample PV Message	C-4
C.3	Time and Distance Reporting	C-5
C.4	Latitude and Longitude Conversion	C-6
C.5	Message Data Strings	C-7
C.6	AL Altitude/Up Velocity	C-8
C.7	AM Alarm	C-8
C.8	AP Auxiliary Port Characteristics	C-9
C.9	CP Compact Position Solution	C-10
C.10	DC Differential Corrections	C-11
C.11	DD Delta Differential Corrections	C-12
C.12	ID Identification Number	C-13
C.13	IP Initial Position	C-14
C.14	LN Long Navigation Message	C-15
C.15	PR Protocol	C-16
C.16	PT Port Characteristic	C-17
C.17	PV Position/Velocity Solution	C-18
C.18	RM Reporting Mode	C-19
C.19	RT Reset Mode	C-20
C.20	ST Status	C-21
C.21	TM Time/Date	C-23
C.22	VR Version Number	C-24
C.23	X1 Extended Status	C-24
C.24	Communication Using TAIP	C-25

C.24.1	Query for Single Sentence.	C-25
C.24.2	Scheduled Reporting Frequency Interval	C-25
C.24.3	The Response to Query or Scheduled Report	C-25
C.24.4	The Set Qualifier	C-26
C.24.5	Sample Communication Session	C-26

D GPSSK User's Guide (TAIP)

D.1	The GPSSK Files	D-1
D.2	TAIP.C Source File	D-2
D.3	GPSSK Start-up	D-2
D.4	On-line Help	D-2
D.5	Connecting the GPS Sensor	D-3

E NMEA 0183

E.1	The NMEA 0183 Communication Interface	E-1
E.2	NMEA 0183 Message Format	E-2
E.3	NMEA 0183 Message Options	E-2
E.4	NMEA 0183 Message Formats.	E-3
E.4.1	GGA - GPS Fix Data	E-3
E.4.2	GLL - Geographic Position - Latitude/Longitude	E-4
E.4.3	GSA - GPS DOP and Active Satellites	E-4
E.4.4	GSV - GPS Satellites in View	E-5
E.4.5	RMC - Recommended Minimum Specific GPS/Transit Data.	E-6
E.4.6	VTG - Track Made Good and Ground Speed	E-6
E.4.7	ZDA - Time & Date	E-7

F ACE II GPS Specifications and Mechanical Drawings

F.1	GPS Receiver.	F-1
F.1.1	General.	F-1
F.1.2	Accuracy.	F-1
F.1.3	DGPS Accuracy	F-1
F.1.4	Datum	F-1
F.1.5	Acquisition Rate.	F-2
F.1.6	Dynamics	F-2
F.2	Environmental Characteristics	F-2
F.2.1	Temperature	F-2
F.2.2	Vibration.	F-2
F.2.3	Altitude	F-2
F.2.4	Humidity.	F-2

F.3	Physical Characteristics	F-3
	Size	F-3
F.3.1	Weight	F-3
F.3.2	Power	F-3
F.4	Input/Output	F-3
F.4.1	Interface	F-3
F.4.2	Protocols Available	F-3
F.5	Pulse Per Second	F-3
F.5.1	Timing	F-3
F.5.2	Pulse Width	F-4
F.5.3	Output	F-4
F.5.4	Electrical.	F-4
F.5.5	Environmental	F-4
F.5.6	Mechanical.	F-4

Glossary

List of Figures

Figure 1-1.	The Module Installed Inside the Interface Unit	1-5
Figure 1-2.	Receiver Module	1-6
Figure 1-3.	Starter Kit Interface Unit	1-7
Figure 1-4.	Open Collector PPS	1-8
Figure 1-5.	Magnetic Mount GPS Antenna.	1-9
Figure 1-6.	Hard Mount GPS Antenna	1-9
Figure 1-7.	Bullet II GPS Antenna	1-9
Figure 1-8.	DC Power Cable	1-10
Figure 1-9.	AC/DC Power Converter.	1-11
Figure 1-10.	Interconnect Diagram	1-12
Figure 2-1.	Motherboard Connection Points	2-1
Figure 2-2.	Removing the Receiver Module	2-2
Figure B-1	TSIPMonitor32 - Serial Port Selection.	B-2
Figure B-2	TSIPMonitor 32 - Main Window	B-2
Figure F-1.	ACE II GPS Circuit Board	F-5
Figure F-2.	ACE II GPS Starter Kit Motherboard	F-6
Figure F-3.	Bullet II Antenna	F-7
Figure F-4.	Bulkhead Antenna	F-8
Figure F-5.	GPS Miniature Antenna	F-9

List of Tables

Table 1-1.	ACE II GPS Starter Kit.	1-4
Table 1-2.	ACE II GPS Modules	1-4
Table 1-3.	ACE II GPS Module Optional Antennas.	1-4
Table 1-4.	Serial Port Pinouts	1-7
Table 2-1.	I/O Connector Signals	2-3
Table 2-2.	Power Requirements	2-4
Table 3-1.	Default Serial Port Characteristics	3-2
Table 3-2.	TSIPCHAT Commands	3-9
Table 4-1.	Default Satellite Mask Settings.	4-3
Table 4-2.	ACE II GPS Operating Limits	4-9
Table A-1.	Automatic Output Packets	A-2
Table A-2.	Automatic Position and Velocity Reports Control Setting Bits	A-3
Table A-3.	Receiver Initialization Commands	A-4
Table A-4.	Output Packets at Power-up	A-4
Table A-5.	Differential GPS Packet TSIP Control Commands (DGPS).	A-5
Table A-6.	Timing Packet TSIP Control Commands	A-5
Table A-7.	Satellite Data Packet Data I/O Descriptions	A-5
Table A-8.	Background Packet Output Messages	A-6
Table A-9.	Supported Auto-Output Packet Command Backward Incompatibility	A-6
Table A-10.	TSIP Command Backward Incompatibility	A-7
Table A-11.	Recommended TSIP Packet Data	A-8
Table A-12.	Standard TSIP Command Packets	A-10
Table A-13.	TSIP Super Command Packets	A-12
Table A-14.	Standard TSIP Report Packets	A-12
Table A-15.	Setup Parameters	A-14
Table A-16.	Command Packet 0x1E Format	A-18
Table A-17.	Command Packet 0x22 Position Fix Mode Select	A-19
Table A-18.	Command Packet 0x23 Data Format.	A-19
Table A-19.	Packet 0x2A Set Reference Altitude Description	A-21
Table A-20.	Packet 0x2A Clear Reference Altitude Only Description	A-21
Table A-21.	Command Packet 0x2B Data Format	A-21
Table A-22.	Command Packet 0x2C Data Format	A-22

Table A-23.	Command Packet 0x2E Data Formats	A-23
Table A-24	Command Packet 0x31 Data Format	A-24
Table A-25	Command Packet 0x32 Data Format	A-24
Table A-26.	Command Packets 0x35 and 0x55 Data Descriptions	A-26
Table A-27.	Command Packet 0x38 Data Formats	A-28
Table A-28.	Command Packet 0x39 Data Formats	A-29
Table A-29.	Command Packet 0x3A Data Format.	A-29
Table A-30.	Command Packet 0x3B Data Format.	A-30
Table A-31.	Command Packet 0x3C Data Format.	A-30
Table A-32.	Command/Report Packet 0x3D Data Format.	A-31
Table A-33.	Report Packet 0x40 Data Format	A-32
Table A-34.	Report Packet 0x41 Data Formats	A-33
Table A-35.	Packets 0x41 and 0x46 Status Code Relationships.	A-33
Table A-36.	Report Packet 0x42 Data Formats	A-34
Table A-37.	Report Packet 0x43 Data Formats	A-34
Table A-38.	Report Packet 0x45 Data Formats	A-35
Table A-39.	Report Packet 0x46 Data Formats	A-36
Table A-40.	Report Packet 0x47 Data Formats	A-36
Table A-41.	Report Packet 0x49 Almanac Health Page Data Formats	A-37
Table A-42.	Report Packet 0x4A Data Formats	A-38
Table A-45.	Report Packet 0x4B Bit Positions and Descriptions	A-39
Table A-43.	Reference Altitude	A-39
Table A-44.	Report Packet 0x4B Data Formats	A-39
Table A-46.	Report Packet 0x4C Data Formats	A-40
Table A-47.	Report Packet 0x4E Data Formats	A-41
Table A-48.	Report Packet 0x4F Data Formats	A-41
Table A-49.	Command Packets 0x55 and 0x35 Data Descriptions	A-42
Table A-50.	Report Packet 0x56 Data Formats	A-43
Table A-51.	Report Packet 0x57 Data Formats	A-43
Table A-52.	Report Packet 0x58 Data Formats	A-44
Table A-53.	Report Packet 0x58 Almanac Data	A-45
Table A-54.	Report Packet 0x58 Almanac Health Data	A-45
Table A-55.	Report Packet 0x58 Ionosphere Data	A-46
Table A-56.	Report Packet 0x58 UTC Data	A-46
Table A-57.	Ephemeris.	A-46
Table A-58.	Report Packet 0x59 Data Formats	A-48
Table A-59.	Report Packet 0x5A Data Formats	A-48
Table A-60.	Report Packet 0x5B Data Formats	A-50

Table A-61.	Report Packet 0x5C Data Formats	A-51
Table A-62.	Report Packet 0x60 Data Formats	A-52
Table A-63.	Report Packet 0x60 Data Formats for Health and Power	A-52
Table A-64.	Command Packet 0x61 Data Formats	A-53
Table A-65.	Report Packet 0x6D Data Formats	A-54
Table A-66.	Set Synchronized Measurement Parameters	A-55
Table A-67.	Request Synchronized Measurement Parameters	A-55
Table A-68.	Set Synchronized Measurement Parameters	A-55
Table A-69.	Synchronized Measurements Report	A-56
Table A-70.	FLAGS1 Bit Assignments	A-57
Table A-71.	Command Packet 70 Data Formats	A-58
Table A-72.	Command Packet 0x71 Data Formats	A-59
Table A-73.	Command Packet 0x73 Report	A-60
Table A-74.	Report 0x74 Field Descriptions	A-60
Table A-75.	Command Packet 0x77 Report	A-61
Table A-76.	Command Packet 0x7A and Report Packet 0x7B Data Formats.	A-62
Table A-77.	Report Packet 0x83 Data Formats	A-63
Table A-78.	Report Packet 0x84 Data Formats	A-64
Table A-79.	Report Packet 0x85 Data Formats	A-64
Table A-80.	Command Packet 0xBB Query Mode Data Format	A-65
Table A-81.	Command and Report Packet 0xBB Field Descriptions	A-65
Table A-82.	Command Packet 0xBC Port Characteristics	A-66
Table A-83.	Command Packet 0x8E-03 Data Formats	A-69
Table A-84.	Command Packet 0x8E-15 Field Descriptions.	A-70
Table A-85.	Command Packet 0x8E-15 Datum Index Field Descriptions	A-70
Table A-86.	Report Packet 0x8F-15 Data Formats	A-71
Table A-87.	Report Packet 0x8F-17 Data Formats	A-72
Table A-88.	Report Packet 0x8F-18 Field Descriptions.	A-72
Table A-89.	Command Packet 0x8E-19 Field Description	A-73
Table A-90.	Command Packet 0x8F-19 Field Descriptions	A-74
Table A-91.	Command Packet 0x8E-20 Field Descriptions.	A-74
Table A-92.	Report Packet 0x8F-20 Data Formats	A-75
Table A-93.	Command Packet 0x8E-26 Definitions	A-77
Table A-94.	Report Packet 0x8F-26 Field Descriptions.	A-77
Table A-95.	TAIP Configuration Request.	A-77
Table A-96.	TAIP Configuration Command Report Data Formats	A-78
Table C-1.	Message Formats	C-2
Table C-2.	Message Format Qualifiers.	C-2
Table C-3.	Sample PV Message Fields.	C-4

Table C-4.	Time and Distance Reporting Message Format Qualifiers	C-5
Table C-5.	Message Data String Descriptions	C-7
Table C-6.	Altitude/Up Velocity Data String Descriptions	C-8
Table C-7.	Auxiliary Port Characteristics Data String Descriptions	C-9
Table C-8.	Compact Position Solution Data String Descriptions	C-10
Table C-9.	DC Delta Differential Corrections Data String Descriptions.	C-11
Table C-10.	DD Delta Differential Corrections Data String Descriptions.	C-12
Table C-11.	Identification Number Data String Descriptions	C-13
Table C-12.	Initial Position Data String Descriptions	C-14
Table C-13.	Long Navigation Message Data String Descriptions	C-15
Table C-14.	PR Data String Descriptions	C-16
Table C-15.	Port Characteristic Data String Descriptions	C-17
Table C-16.	Position/Velocity Solution Data String Descriptions.	C-18
Table C-17.	Reporting Mode Data String Descriptions	C-19
Table C-18.	Reset Mode Data String Descriptions	C-20
Table C-19.	Data String Hex Characters.	C-21
Table C-20.	Tracking Status Code	C-21
Table C-21.	Error Codes: Nibble 1	C-21
Table C-22.	Error codes: Nibble 2	C-22
Table C-23.	Error Codes: Nibble 4	C-22
Table C-24.	TM Time/Data Data String Descriptions	C-23
Table C-25.	Version Number Data String Descriptions	C-24
Table E-1.	NMEA 0183 Characteristics	E-1
Table E-2.	ACE II GPS NMEA Messages	E-3
Table E-3.	GGA - GPS Fix Data Message Parameters.	E-3
Table E-4.	GLL - Geographic Position - Latitude / Longitude Message Parameters	E-4
Table E-5.	GSA - GPS DOP and Active Satellites Message Parameters	E-4
Table E-6.	GSV - GPS Satellites in View Message Parameters	E-5
Table E-7.	RMC - Recommended Minimum Specific GPS / Transit Data Message Parameters	E-6
Table E-8.	VTG - Track Made Good and Ground Speed Message Parameters	E-6
Table E-9.	ZDA - Time & Date Message Parameters	E-7

Preface

The Global Positioning System (GPS) is a satellite based navigation system operated and maintained by the U.S. Department of Defense. The GPS consists of a constellation of 24 satellites providing world-wide, 24 hour, three dimensional (3-D) coverage. Although originally conceived for military needs, GPS has a broad array of civilian applications including surveying, marine, land, aviation, and vehicle navigation. GPS is the most accurate technology available for vehicle navigation.

As a satellite based system, GPS is immune to the limitations of land based systems such as Loran. Loran navigation is limited in coverage and is encumbered by adverse weather. In addition, the accuracy of Loran navigation varies with geographic location and, even under ideal conditions, cannot compare with GPS. By computing the distance to GPS satellites orbiting the earth, a GPS receiver can calculate an accurate position. This process is called satellite ranging. A 2-D position calculation requires three satellite ranges. A 3-D position calculation, which includes altitude, requires four satellite ranges. GPS receivers can also provide precise time, speed, and course measurements which are beneficial for vehicle navigation.

Differential GPS (DGPS) is a sophisticated form of GPS navigation which provides even greater positioning accuracy. Differential GPS relies on error corrections transmitted from a GPS receiver placed at a known location. This receiver, called a reference station, calculates the error in the satellite range data and outputs corrections for use by other GPS receivers. These GPS receivers are designated as mobile units and can be dispersed as far as 100 km from the base station. Differential GPS eliminates virtually all the measurement error in the satellite ranges and enables a highly accurate position calculation. The ACE II GPS is differential-ready for applications requiring DGPS accuracy.

Scope and Audience

Even if you have used other Global Positioning System (GPS) receivers, we recommend that you spend some time reading this manual. The following section provides you with a guide to this manual, as well as to other documentation included with this product.

ACE II GPS Manual Organization

All of the information required to integrate and operate the ACE II GPS is contained in this manual. This manual contains the following chapters and appendices:

- Chapter 1: Starter Kit
- Chapter 2: Hardware Integration
- Chapter 3: Software Interface
- Chapter 4: Operation and Performance
- Appendix A: Trimble Standard Interface Protocol
- Appendix B: TSIP Toolkit User's Guide
- Appendix C: Trimble ASCII Interface Protocol (TAIP)
- Appendix D: GPSSK User's Guide (TAIP)
- Appendix E: NMEA 0183
- Appendix F: Specifications and Mechanical Drawings
- Glossary

The ACE II GPS is easy to integrate and simple to use. Before proceeding with Chapter 1, please review the information contained in this *Preface* for an overview of the Global Positioning System.

Technical Assistance

If you have problems and cannot find the information you need in this document, call the Trimble Technical Assistance Center (TAC). The phone numbers are:

- +1-800-SOS-4TAC (North America)
- +1-408-481-6940 (International)
- +1-408-481-6020 (FAX)

You can call the Technical Assistance Center phones between 6 AM (0600) to 5:30 PM (1730) Pacific Standard Time. A support technician will take your call, help you determine the source of your problem, and provide you with any technical assistance you might need.

Email

You can send email to the Technical Assistance Center at any time. A support technician will respond to your email questions or comments. The email address is:

trimble_support@trimble.com.

Worldwide Web

Check the Trimble worldwide web site on the Internet (<http://www.trimble.com>) for the latest news on new products and releases.

Internet FTP Address

You can visit the Trimble Public FTP site at any time to access software patches, utilities, service bulletins, and FAQs. The FTP site address is:

`ftp.trimble.com/pub/sct/embedded/bin.`

FaxBack

FaxBack is a completely automated fax response system for selecting documents and catalogs (lists of available documents) to be faxed back to a fax machine. Call from a tone-dialing phone and FaxBack guides you through the call by playing a pre-recorded voice message.

The FaxBack system is available 24 hours a day, seven days a week. You can order a variety of documents, including; data sheets, application notes, technical documentation, configuration guides, assembly drawings, and general information.

To call the FaxBack service, dial the following number and follow the instructions:

+1-408-481-7704

Reader Comments

Comments and suggestions can be sent to:

Trimble Navigation Limited
645 North Mary Avenue
Post Office Box 3642
Sunnyvale, CA 94088-3642

All comments and suggestions become the property of Trimble Navigation Limited.

Document Conventions

<i>Italics</i>	Software menus, menu commands, dialog boxes and fields.
SMALL CAPITALS	DOS commands, directories, filenames, and filename extensions.
Courier	Represents what is printed on the computer screen.
Courier Bold	Information to be typed in a software screen or window.
[Return] or [Ctrl] + [C]	Identifies a hardware function key or key combination that must be pressed on a computer keyboard.
Helvetica	Bold represents a software command button.

Notes, Tips, Cautions, and Warnings

Notes, tips, cautions, and warnings are used to emphasize important information.



Note – Notes give additional significant information about the subject to increase your knowledge, or guide your actions. A note can precede or follow the text it references.



Tip – Indicates a shortcut or other time or labor-saving hint that can help you make better use of the product.



Caution – Cautions alert you to situations that could cause hardware damage or software error. A caution precedes the text it references.



Warning – Warnings alert you to situations that could cause personal injury or unrecoverable data loss. A warning precedes the text it references.

1 Starter Kit

The ACE II GPS, based on Sierra™ GPS technology, delivers an unmatched level of performance for embedded GPS applications. Sierra technology is Trimble's 8-channel GPS architecture based on two ASICs, the Scott RF ASIC and the Scorpion DSP.

The Scott RF ASIC features:

- Double down-conversion process
- Higher sensitivity
- Lowest power consumption

The double down-conversion process improves immunity to in-band jammers. The system provides a higher sensitivity which allows ACE II GPS to track weak satellites and improves position availability in environments with obscured coverage.

The Scorpion DSP ASIC provides the following features in a single package:

- 8-channel DSP with 4 correlators per channel
- 32 bit microprocessor
- Real-time clock
- DUART

The 8-channel, 32-correlator design provides extremely fast cold starts while delivering 2 meter DGPS performance. The high level of integration provides a small footprint (3.25" x 1.83" x 0.45) and contributes to fast GPS signal acquisition. The combination of small size and low power consumption allows ACE II GPS to be embedded in small battery operated devices and in devices where heat dissipation must be minimized.

The Starter Kit makes it simple to evaluate the ACE II GPS module's exceptional performance. The kit includes the following:

- ACE II GPS receiver installed inside an interface unit
- Magnetic mount antenna
- AC power adapter
- Serial interface cable
- GPS Tool Kit Software used to communicate with the GPS module

The interface unit is a sturdy metal enclosure containing an interface motherboard. The motherboard accepts 9 - 32 VDC power and provides regulated +5V and +3.6V BBU power to the ACE II GPS receiver module. The motherboard also provides two RS-232 connectors for quick and direct connection to a PC COM port. The ACE II GPS board can be removed from the motherboard for integration into the user's application (see Chapter 2, Hardware Integration).

1.1 ACE II GPS Overview

The ACE II GPS is a complete 8-channel parallel tracking GPS receiver designed to operate with the L1 frequency, Standard Position Service, Coarse Acquisition code. Using two highly integrated Trimble custom integrated circuits, the receiver is designed in a modular format especially suited for embedded applications. The ACE II GPS features Trimble's latest signal processing code, a high-gain RF section for compatibility with standard 25 dB active gain GPS antennas, and a CMOS TTL level pulse-per-second (PPS) output for timing applications or as a general purpose synchronization signal.

The ACE II GPS acquires a position fix with minimal delay after power cycling. The information necessary to help track satellites is stored in RAM using backup power for the following:

- Almanac
- Ephemeris
- Real-time clock
- Last position

User settings, including port parameters and receiver processing options, are stored in a non-volatile electrically erasable ROM (EEROM) that does not require backup power.

The ACE II GPS has two independently configurable serial I/O communication ports. The dual data I/O port characteristics and other options are user programmable and stored in non-volatile memory.



Warning – When customizing port assignments or characteristics, confirm that your changes do not affect your ability to communicate with the receiver module (see Chapter 3, Software Interface).

1.1.1 Interface Protocols

The ACE II GPS operates using either of three protocols — Trimble Standard Interface Protocol (TSIP), Trimble ASCII Interface Protocol (TAIP), and NMEA 0183. The ACE II GPS also supports RTCM SC-104 for DGPS. The factory default settings are:

- Port 1 TSIP or TAIP bi-directional
- Port 2 NMEA 0183 out/RTCM SC-104 V2.1 in

Protocol selection and port assignments are user configurable.

Port 1

TSIP is a powerful binary packet protocol that allows the system designer maximum configuration control over the GPS receiver for optimum performance in any number of applications. TSIP supports over 40 commands and their associated response packets for use in configuring the ACE II GPS receiver module to meet user requirements.

TAIP is designed for easy integration into systems using ASCII characters only.

Port 2

NMEA 0183 is an industry standard protocol common to marine applications. NMEA provides direct compatibility with other NMEA-capable devices such as chart plotters, radars, etc. The ACE II GPS receiver module supports most NMEA messages for GPS navigation. NMEA messages and output rates can be user selected as required.

DGPS

The ACE II GPS receiver module can be configured for RTCM SC-104 input which is the GPS industry standard for differential correction data. The receive side of port 2 is factory configured to accept RTCM data.

1.1.2 Starter Kit Components

The ACE II GPS is available in a developer's Starter Kit or as individual boards. The Starter Kit includes all the components necessary to quickly test and integrate the module.

The Starter Kit components and the accessory part numbers are listed in Table 1-1 and Table 1-2, and Table 1-3.

Table 1-1. ACE II GPS Starter Kit

Starter Kit Part Reference	Part Number
ACE II GPS Starter Kit	36831-00
Magnetic Mount GPS Antenna with Cable	28367-00
AC Power Adapter	29938
Power Cable	20260
Interface Cable DB9M/DB9F (pin to pin)	19309-00
ACE II Toolkit Disk	37116-01
System Designer Reference Manual	39538-00

Table 1-2. ACE II GPS Modules

Module Reference	Part Number
ACE II GPS	36830-50

Table 1-3. ACE II GPS Module Optional Antennas

Antenna Reference	Part Number
Hard Mount GPS Antenna	28367-70
Rooftop Antenna Kit with 75 foot cable	23726-00



Note – Part numbers are subject to change. Confirm part numbers with your Trimble representative when placing your order.

1.2 GPS Receiver Module

In the Starter Kit, the ACE II GPS is installed on an interface motherboard which is housed in a metal enclosure (see Figure 1-1). This packaging simplifies testing and evaluation of the module by providing an RS-232 serial interface which is compatible with most PC communication ports, and by providing a DC power supply which converts a 9 to 32 VDC input to the regulated 5 volts required by the module. The DB9 connectors provide an easy connection to the PC's serial port using the interface cable provided in the kit. The metal enclosure protects the module and motherboard for testing outside of the laboratory environment.

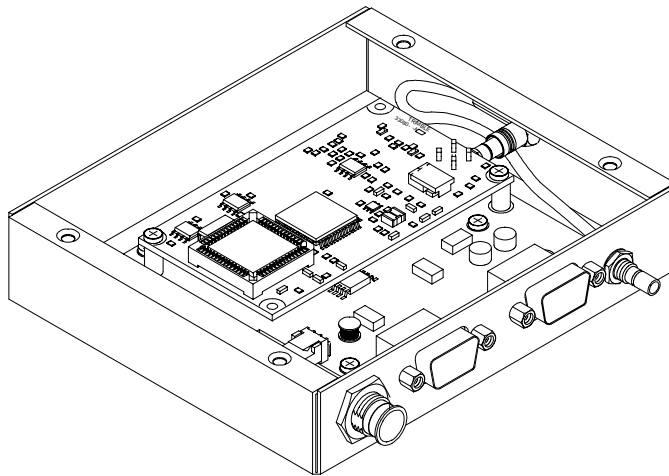

Figure 1-1. The Module Installed Inside the Interface Unit

The receiver module (see Figure 1-2) consists of a single 3.25" x 1.83" x 0.45" module. A standard SMB RF connector (J1) supports the GPS antenna connection. The center conductor supplies +5 VDC for the Low Noise Amplifier of the active antenna. An 8-pin, 0.1 inch header (J4) supports the serial interface (CMOS TTL level), the pulse-per-second (PPS) signal (CMOS TTL level), and the input power (+5 VDC). This module connects to the motherboard via the 8-pin header and is secured by two standoffs. An RF-interface cable connects the antenna port to an SMB connector on the enclosure panel.

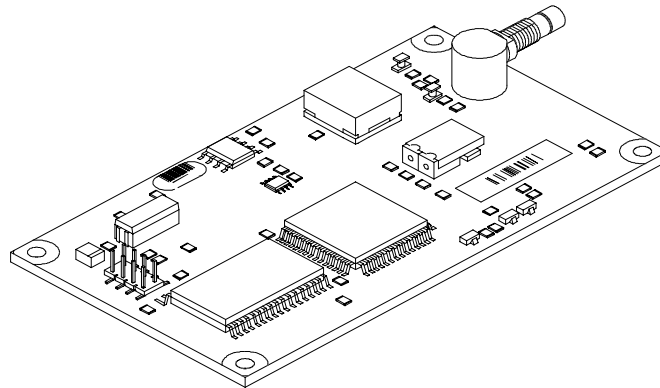

Figure 1-2. Receiver Module



Note – The receiver included in the Starter Kit contains a socket for the firmware ROM. This socketed board may be used to evaluate future releases of firmware. The standard OEM module is not equipped with a socket.

The interface motherboard includes a 9 to 32 VDC switching power supply which provides a regulated +5 VDC to the receiver. It also converts the TTL-level I/O to RS-232 for a direct interface to a computer. The motherboard provides an open-collector interface for the PPS and also includes a 3.6V lithium backup battery enabling quick hot starts. The Starter Kit includes an AC/DC converter for powering the module from an AC wall socket. The metal enclosure (see Figure 1-3) provides 2 interface port connectors, an antenna connector and a power connector. The mounting plate is secured to the metal enclosure with four screws. The eight pin header on the receiver module plugs into the corresponding 8-pin socket on the motherboard.

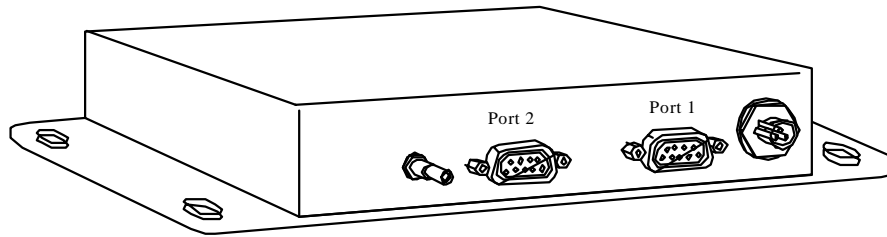

Figure 1-3. Starter Kit Interface Unit

1.2.1 Starter Kit Serial Port Interface

The GPS receiver is a DCE (Data Communication Equipment) device. To connect to a host computer, or DTE (Data Terminal Equipment) device, use a straight through cable. To connect a Differential Radio (DCE device) to the receiver (DCE Device) use a cross over cable or null modem cable.

Table 1-4. Serial Port Pinouts

Port 1	
Pin	Description
1	NC
2	TX
3	RX
4	NC
5	GND
6	NC
7	NC
8	NC
9	PPS Out

Port 2	
Pin	Description
1	NC
2	TX
3	RX
4	NC
5	GND
6	NC
7	NC
8	NC
9	PPS Out

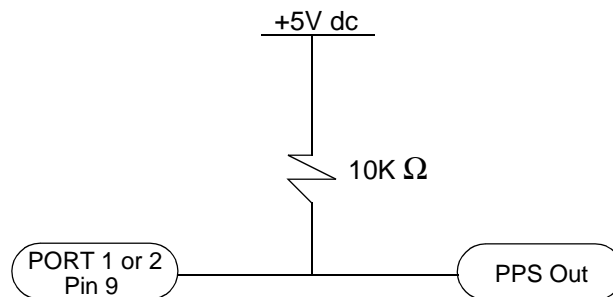

Figure 1-4. Open Collector PPS

Note – The 1PPS signal is an open collector interface on pin 9 of Ports 1 and 2 on the Starter Kit interface unit. The polarity of the PPS signal is an inverted, 10 μ s negative going pulse with the falling edge synchronized to UTC. To pull up the 1PPS, use a 10K pull up resistor as illustrated in Figure 1-4.

1.3 Antenna

The GPS antenna receives the GPS satellite signals and passes them to the receiver. Because the GPS signals are spread spectrum signals in the 1575 MHz range and do not penetrate conductive or opaque surfaces, the GPS antenna must be located outdoors with a clear view of the sky. The ACE GPS requires an *active* antenna. The received GPS signals are very low power, approximately -140 dB, at the surface of the earth. Trimble's active antennas include a preamplifier that filters and amplifies the GPS signals before delivery to the receiver.

Trimble offers a variety of antennas for use with the ACE GPS. The compact magnetic mount GPS antenna and integral cable supplied with the Starter Kit is ideal for portable and mobile applications. A permanent, bulkhead mount antenna is also available. A compact, pole-mount rooftop antenna is available for fixed-site installations. See Appendix F for mechanical outline drawings of the GPS antennas.



Warning – When magnetic-mount or permanent-mount GPS antennas are installed on a metal surface for prolonged periods, care must be taken to insulate the antennas in order to prevent galvanic corrosion.

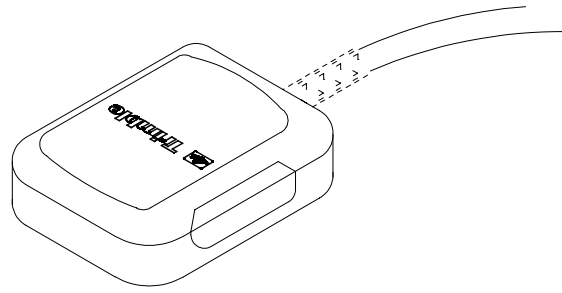

Figure 1-5. Magnetic Mount GPS Antenna

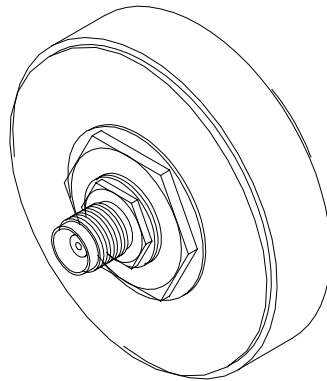

Figure 1-6 Hard Mount GPS Antenna

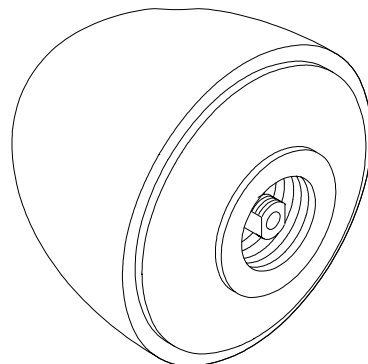

Figure 1-7. Bullet II GPS Antenna

1.4 Power

The receiver module is designed for embedded applications and requires a regulated +5.0 VDC input (+4.75 to +5.25 VDC). See section 2.3 on page 3 for detailed specifications. In the Starter Kit, the motherboard includes a DC power regulator which converts a 9 to 32 VDC input to the regulated 5 VDC required by the module. Power can be applied to the Starter Kit module using one of two options: the DC power cable (see Figure 1-8) or the AC/DC power converter (see Figure 1-9).

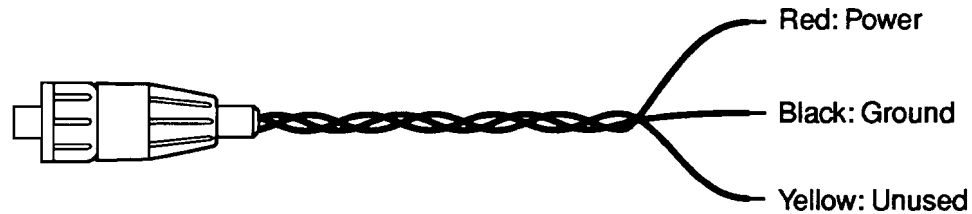

Figure 1-8. DC Power Cable

The DC power cable is ideal for bench-top or automotive testing environments. The power cable is terminated at one end with a 3-pin plastic connector which mates with the power connector on the metal enclosure. The unterminated end of the cable provides easy connection to a DC power supply. Connect the red power lead to a source of DC positive +9 to +32 VDC, and connect the black power lead to ground. This connection supplies power to both the receiver module and the antenna. The combined power consumption of the receiver module and the antenna is 200 milli-amps.



Note – The yellow wire is not used in the Starter Kit. Battery back-up is provided by a factory installed 3.6V lithium battery on the motherboard.

The AC/DC power converter may be used as an alternate power source for the Starter Kit module. The AC/DC power converter converts 110 or 220 VAC to a regulated 12 VDC compatible with the Starter Kit module. The AC/DC power converter output cable is terminated with a 3-pin connector compatible with the power connector on the metal enclosure. The AC power cable is not provided in the kit, since this cable is country-specific. The input connector is a standard 3-prong connector used on many desktop PCs.

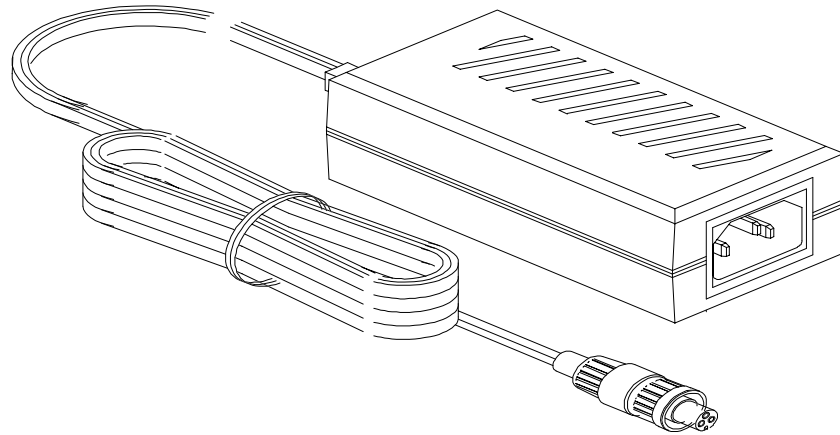

Figure 1-9. AC/DC Power Converter

1.5 Hardware Setup

The ACE GPS supports TSIP, TAIP, and NMEA protocols. Port 1 is usually used for TSIP or TAIP I/O and port 2 is used to input RTCM SC-104 corrections and output NMEA messages. Follow the steps below to setup the Starter Kit. Figure 1-10 illustrates the setup.

1. For TSIP or TAIP protocols, connect one end of the 9-pin serial interface cable to Port 1 (or Port 2 to view NMEA data) of the receiver module. Connect the other end of the cable to COM1 or COM2 on a PC. A 9-pin-to-25-pin adapter may be required for the serial interface connection to a PC, if your PC has a 25-pin communication port.
2. Connect the antenna cable to the interface unit. This connection is made by pushing the antenna cable connector onto the SMB connector on the unit (to remove the antenna cable, simply pull the antenna connector off of the SMB connector). Place the antenna so that it has a clear view of the sky.
3. Using either the DC power cable or AC/DC power converter, connect to the 3-pin power connector on the interface unit.
 - DC Power Cable — Connect the terminated end of the power cable to the power connector on the interface unit. Connect the red lead to DC positive voltage (+9 to +32 VDC) and black power lead to DC ground. The yellow wire is not used. Switch on the DC power source.
 - AC/DC Power Converter — Connect the output cable of the converter to the 3-pin power connector on the interface unit. Using the appropriate 3-prong AC power cable (not provided), connect the converter to an AC wall socket (110 VAC or 220 VAC). The AC power cable is not provided in the Starter Kit.

Figure 1-10. Interconnect Diagram

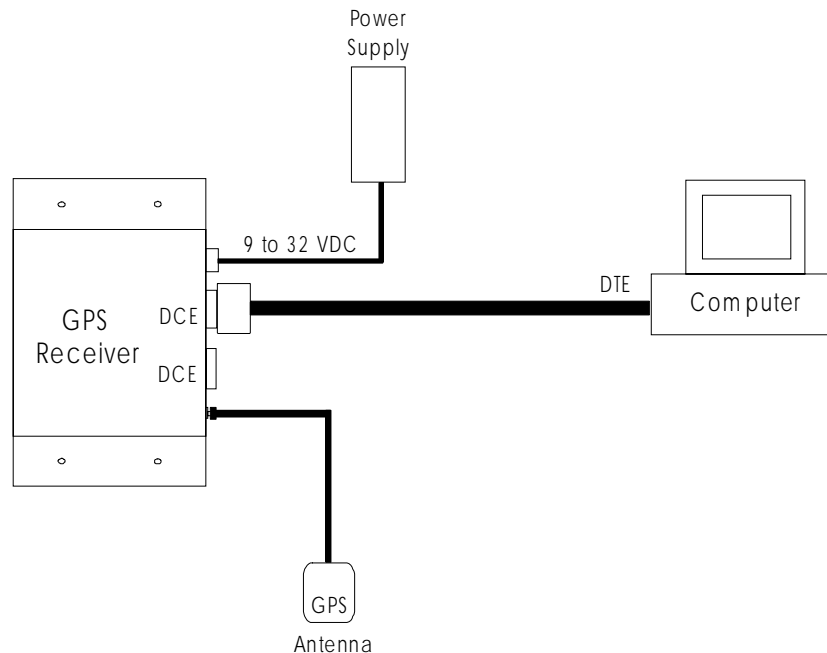

1.6 Running the TSIPMonitor32 Interface Program

The Starter Kit includes a disk containing TSIP interface programs which run on a PC-DOS platform, as well as Windows 95/NT platforms. These programs aid system integrators in monitoring the receiver module's performance and in developing the software interface for the GPS module. The TSIP programs are described in detail in Appendix B, TSIP User's Guide.

1. Connect one end of the serial interface cable to Port 1 of the Starter Kit interface unit. Connect the other end of the cable to the serial port of your PC.
2. Turn on the DC power source or plug in the AC/DC converter.
3. Insert the GPS Tool Kit disk in the disk drive.
4. Refer to the Readme.txt file for complete instructions.
5. The TSIPMonitor32 program may be run directly off the diskette or the entire contents of the diskette may be copied onto your computer's hard drive. To run the program off the diskette, type A:TSIPMonitor32.exe.

6. Once the TSIPMonitor32 screen appears, the lower left hand screen will display the TX and RX status. If the receiver is communicating to the host software, a blinking green status will appear depending if the receiver is sending a command, or transmitting a report.
7. Once a GPS antenna is connected to a receiver and the receiver has achieved a position fix, the transmitted position reports will be displayed in the position field, as well as time, velocity, satellites tracked, and GPS receiver status. The receiver will send a health report every few seconds, even when no satellites are being tracked.

If the TSIPMonitor32 program displays a question mark (?), the receiver has not reported a status for this field. If the ? never disappears in the data field, then the GPS module may not be communicating with the computer. If this occurs, re-check the interface cable connections and verify the serial port selection. If the communication failure still occurs after checking all connections and settings, please call the Trimble Technical Assistance Center (TAC) for assistance. 1 (800) 481-8000 ext.8527.

2 Hardware Integration

The integration of the ACE II GPS receiver module is discussed in two sections: Hardware Integration and Software Interface. This chapter, Hardware Integration, includes instructions for mounting the GPS module and physically connecting the module to the antenna, the host processor, and the power source. Chapter 3, Software Interface, provides guidelines for configuring the ACE II GPS receiver module to communicate with the host processor.

2.1 The ACE II GPS Receiver Module

In the Starter Kit, the ACE II GPS receiver module is installed on the interface motherboard to facilitate testing and evaluation. The receiver module can be detached from the motherboard for installation into a specific device.

The receiver module is connected to the motherboard at four points: the antenna connector, the interface connector, and two standoffs (see Figure 2-1). Follow the steps on the following page to remove the receiver module from the motherboard.



Note – The ACE II motherboard will also accept an SVEE6-CM3 module.

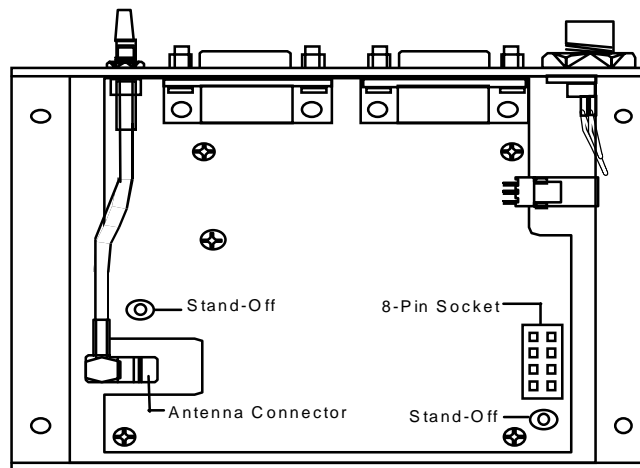

Figure 2-1. Motherboard Connection Points



Caution – Before disassembling the interface unit, disconnect the unit from any external power source and confirm that both you and your work surface are properly grounded for ESD protection. The interface unit motherboard contains a 3.6V lithium battery. Exercise caution when removing it from the ACE II GPS unit.

1. Remove the four screws which secure the bottom plate to the base of the metal enclosure. Set the bottom plate aside.
2. Remove the two screws securing the ACE II GPS module to the standoffs on the motherboard. These screws are located at opposite ends of the receiver module (see Figure 2-2).

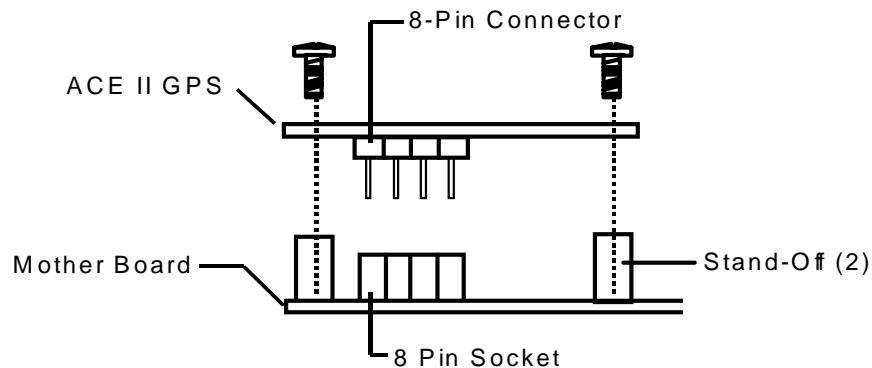

Figure 2-2. Removing the Receiver Module

3. Carefully pull the module straight off the motherboard to disengage the 8-pin header from the 8-pin socket on the motherboard (see Figure 2-2). Do not rotate or flex the module while disengaging the header, since this could damage the connector or the board components. Pull straight up, keeping the ACE II GPS parallel to the motherboard.
4. Disconnect the RF cable connecting the ACE II GPS module to the SMB connector on the enclosure. This connection was made by pushing the antenna cable connector onto the SMB connector on the receiver. To remove the antenna cable, grasp the cable connector and pull it straight off of the antenna connector. Do not twist the cable or attempt to pull it off at an angle, as this may damage the connector.
5. To reinstall the ACE II GPS board in the motherboard, follow steps 1 - 4 in reverse order.



Note – The ACE II GPS is designed for embedded applications. The digital I/O lines and power lines are not designed with additional ESD protection as a stand-alone module would be. Use standard CMOS ESD handling precautions when removing and installing the receiver module.

2.2 Interface Connector

The ACE II GPS power and data I/O functions are integrated into a single 8-pin header 0787connector, J3. The J3 connector uses 0.150 inch (3.8 mm) pins on 0.0787 inch (2 mm) spacing (See Appendix F, ACE II GPS Specifications and Mechanical Drawings).

Table 2-1. I/O Connector Signals

Pin #	Function	Description
1	TXD 2	Port 2 transmit, CMOS/TTL
2	Prime Power	5VDC \pm 5%, 150 mA typical
3	TXD 1	Port 1 transmit, CMOS/TTL
4	Backup Power	+3.2VDC to +5.25VDC, 2 μ A typical
5	RXD 1	Port 1 receive, CMOS/TTL
6	1 PPS	Pulse-Per-Second, CMOS/TTL
7	RXD 2	Port 2 receive, CMOS/TTL
8	GND	Ground, Power and Signal

Pins 3 and 5 on J3 are also referred to as the primary serial port. Pins 1 and 7 are also referred to as the secondary serial port.

2.3 Power Requirement

The ACE II GPS receiver module requires +5 volts DC \pm 5% at 175 mA, typical excluding the antenna. For power-on surge design considerations, the prime power should be able to source up to a maximum load of 225 mA. The on-board capacitance on prime power is 10 μ F. An important design consideration for power is the receiver module's internal clock frequency at 12.504 MHz \pm 3 KHz. Interference spurs on prime power in this narrow frequency band should be kept to less than 1mV.

The receiver does not require any special power up or down sequencing. The receiver power is supplied through pin 2 of the I/O connector. Refer to Table 2-2 for the +5 VDC power specifications.

The ACE II GPS module provides an input for battery back-up (BBU) power to keep the module's RAM memory alive and to power the real-time clock when the receiver's prime power is turned off. RAM memory is used to store the GPS almanac, ephemeris, and last position. User configuration data, including port parameters and receiver processing options, are stored in non-volatile EEROM which does not require back-up power. By using battery back-up, time to first fix is reduced to 20 seconds (typical). Though not required, providing BBU power can reduce power-on time. A 3.6 volt lithium battery used for back-up power can last up to five years.



Note – 3.2V is the minimum allowable voltage. When the power output drops below 3.2V, the real-time clock may not operate over the specified full temperature range. This can also significantly extend the time to first fix.

Table 2-2. Power Requirements

Signal	Voltage	Current	J4 Pin
VCC	+4.75 to +5.25	200 mA	2
Battery Backup	+3.2 to +5.25	0µA with prime power; 4µA @ 3.5V, 25°C without prime power	4
Ground	0	-	8

The ACE II GPS receiver module will maintain full performance specification when the prime power line is coupled with less than 100 mV of ripple noise, peak to peak from 1Hz to 1MHz.



Note – The ACE II GPS Starter Kit motherboard contains a 3.6V lithium battery.

2.4 Serial Interface

As an embedded design, the ACE II GPS receiver module provides direct CMOS compatible TTL level serial I/O. The RX and TX signals on the J3 I/O connector are driven directly by the DUART on the ACE II GPS. Interfacing these signals directly to a DUART in your application circuitry provides direct serial communication without the complication of RS-232 or RS-422 line drivers.



Note – The serial I/O signals on J3 are TTL level. They are not inverted or driven to RS-232 levels.

2.5 Pulse Per Second

A ten microsecond wide, CMOS compatible TTL level pulse is available on Pin 6 of the J3 I/O connector. This pulse is issued once per second with the rising edge of the pulse synchronized with UTC. The pulse will be shaped by the distributed impedance of the attached signal line and input circuit. The rising edge is typically less than 20 nSec. The falling edge should not be used.

The timing accuracy is ± 100 nanosecond (1σ) and is available only when valid position fixes are being reported. Repeatability checks of 10 sets of 100 one second samples taken over a period of 20 minutes showed an average variation of approximately 100 nanoseconds (not allowing for SA).

2.6 Mounting

The ACE II GPS provides four 0.095 inch mounting holes that will accept 3/16 inch round or hex standoffs with 3/8 inch height, and # 2-56 or M2 mounting screws. Space constrained environments may require a different stand-off. Refer to the mechanical outline drawing in Appendix F for dimensions and clearances.

3 Software Interface

This chapter describes the ACE II GPS software interface, the start-up characteristics for the interface protocols, a description of the receiver operating modes, and a brief discussion of the interface protocols.

3.1 Start-up

ACE II GPS is a complete 8-channel parallel tracking GPS receiver designed to operate with the L1 frequency, standard position service, Coarse Acquisition code. Using two highly integrated Trimble custom integrated circuits, the receiver is designed in a modular format especially suited for embedded applications.

When connected to an external GPS antenna, the receiver contains all the circuitry necessary to automatically acquire GPS satellite signals, track up to 8 GPS satellites, and compute location, speed, heading, and time. The receiver will automatically begin to search for and track GPS satellite signals at power-up.

The performance of a GPS receiver at power-on is determined largely by the availability and accuracy of the satellite ephemeris data and the availability of a GPS system almanac. Refer to Chapter 4 for additional information. The first time the receiver is powered-up, it is searching for satellites from a cold start (no almanac). While the receiver will begin to compute position solutions within the first two minutes, the receiver must continuously track satellites for approximately 15 minutes to download a complete almanac. This initialization process should not be interrupted. With a complete almanac and back-up power, the time to first fix can typically be shortened to less than 45 seconds. The receiver will respond to commands almost immediately after power-up.

3.2 Software Tool Kits

The Starter Kit includes a Software Developers Tool Kit to support the TSIP and TAIP protocols. The Kit contains a user-friendly program to communicate with the receiver and includes sample C source code and reusable routines to aid in developing applications. The following Appendices provide additional information:

- Appendix A, Trimble Standard Interface Protocol (TSIP)
- Appendix B, TSIP Toolkit User's Guide
- Appendix C, Trimble ASCII Interface Protocol
- Appendix D, GPSSK User's Guide (TAIP)
- Appendix E, NMEA 0183

3.3 Communicating with the ACE II GPS Module

The ACE II GPS supports three message protocols: TSIP, TAIP, and NMEA. The protocols are discussed at the end of this chapter, and are explained in detail in Appendices A through E.

Communication with the ACE II GPS module is through two CMOS compatible, TTL level serial ports. The port characteristics can be changed to accommodate your application requirements. Port parameters are stored in a non-volatile, electrically erasable ROM (EEPROM) that does not require backup power. Table 3-1 lists the default characteristics for each port.

Table 3-1. Default Serial Port Characteristics

Port	Input Protocol	Default Setup	Output Language	Default Setup
1	TAIP	Baud Rate: 4800 Data Bits: 8 Parity: None Stop Bits: 1 No Flow Control	TAIP	Baud Rate: 4800 Data Bits: 8 Parity: None Stop Bits: 1 No Flow Control
1	TSIP	Baud Rate: 9600 Data Bits: 8 Parity: Odd Stop Bits: 1 No Flow Control	TSIP	Baud Rate: 9600 Data Bits: 8 Parity: Odd Stop Bits: 1 No Flow Control
2	RTCM	Baud Rate: 4800 Data Bits: 8 Parity: None Stop Bits: 1 No Flow Control	NMEA	Baud Rate: 4800 Data Bits: 8 Parity: None Stop Bits: 1 No Flow Control

Any standard serial communications program, such as Windows Terminal or PROCOMM, can be used with the TAIP or NMEA interface protocol. TSIP is a binary protocol and outputs raw binary serial data onto the screen which cannot be read. Trimble encourages the use of the software tool kit provided for TSIP. The serial port drivers in the Trimble tool kit, TSIPCHAT, match the ACE II GPS serial port characteristics. The TSIPPRNT program converts binary data logged with the TSIPCHAT program into text that may be printed and displayed.



Warning – When using the TSIP protocol to change port assignments or characteristics, confirm that your changes do not affect the ability to communicate with the receiver module.

3.4 Protocol Summary

The ACE II GPS receiver is shipped from the factory with the following configuration:

- TSIP bi-directional
 - Port 1: 9600 baud 8-odd-1
- NMEA 0183 out/RTCM SC-104 V2.1
 - Port 2: 4800 baud 8-none-1

The receiver can easily be reconfigured for different protocols, ports, baud rate and parity settings. These settings are kept in BBRAM (Battery Backed Random Access Memory) and can be saved into non-volatile memory if desired. Use the following commands:

- TSIP command: 0xBC
- TAIP command: PT, PR

Refer to Appendix A, Section A.3, Customizing Receiver Operations, for additional information on protocols.

3.4.1 TSIP Data Output

The Trimble Standard Interface Protocol (TSIP) is the native language for the ACE II GPS. TSIP is a binary language with a wide variety of commands and reports. TSIP reports can be output automatically, or they can be output as responses to queries. The format of the automatic reports can be easily configured. The receiver is factory configured for single precision Latitude-Longitude-Altitude. Report formats can be modified and position and velocity formats can be customized. Guidelines for making these modifications are provided in Section 3.7, *Configuring the ACE II GPS Receiver Protocols*, and Appendix A.

The TSIPCHAT program in the ACE II GPS Starter Kit permits using a computer keyboard to send the Request Packets to the GPS receiver. Responses are displayed on a DOS computer screen in ASCII format. C source code routines for TSIPCHAT are also provided in the Starter Kit. C source can be used as a software design guide by programmers who need to communicate system integration information with the ACE II GPS.

3.4.2 TAIP Data Output

The Trimble ASCII Interface Protocol (TAIP) is a Trimble-specified digital communication interface based on printable ASCII characters over a serial data link. TAIP interface provides the means to configure the ACE II GPS receiver to output various sentences in response to query or on a scheduled basis. TAIP messages may be scheduled for output at a user specified rate starting on a given epoch from top of the hour. For communication robustness, the protocol optionally supports checksums on all messages. It also provides the user with the option of tagging all messages with the unit's user specified identification number (ID). This greatly enhances the functional capability of the unit in a network environment. This protocol is described in Appendix C, Trimble ASCII Interface Protocol (TAIP).

The receiver can be configured to TAIP with the TSIPCHAT program contained in the Toolkit. (For detailed information on this program, refer to Section 3.7, *Configuring the ACE II GPS Receiver Protocols*.) The program stores these settings, along with all the other defaults, to non-volatile memory. The GPSSK program can now be used to control and re-configure the receiver.

Receiver configurations created in GPSSK can be stored in non-volatile memory using the RT command. As mentioned above, the receiver ports can also be set to TAIP through a TSIP port using TSIPCHAT and the TSIP command 0xBC.

3.4.3 NMEA 0183 Data Output

The National Marine Electronics Association (NMEA) protocol is an industry standard data protocol which was developed for the marine industry. Trimble has chosen to adhere stringently to the NMEA 0183 data specification as published by the NMEA.

NMEA data is output in standard ASCII sentence formats. Message identifiers are used to signify what data is contained in each sentence. Data fields are separated by commas within the NMEA sentence. In the ACE II GPS, NMEA is an output only protocol. The NMEA protocol is described in detail in Appendix E, NMEA 0183.

The receiver is shipped from the factory with NMEA output on Port 2. Port 2 settings can be changed using TSIPCHAT and command 0xBC. TSIP command 0x7A changes the NMEA output sentences and output rates. The new settings are saved to BBRAM or they can be saved to non-volatile memory using TSIP command 0x8E-26.

Note – Although the Trimble ACE II GPS supports seven NMEA sentences that contain GPS information, the factory default setting for the ACE II GPS module only outputs the GGA and VTG data strings. To change the output interval or sentence output, use TSIP Command Packet 7A.

3.5 Timing Applications

The ACE II GPS is an excellent source for accurate system timing. Two examples of an application requiring accurate time are environmental data acquisition and synchronization of communications networks. The timing functions of the receiver are supported by the TSIP protocol. See Report Packet 41 in Appendix A for a description of the time function reports for TSIP.



Note – Note that GPS time differs from UTC (Universal Coordinated Time) by a variable integer number of seconds: $UTC = (GPS\ time) - (GPS\ UTC\ Offset)$

As of January 1999, the GPS UTC offset was 13 seconds. The offset increases by 1 second approximately every 18 months. System designers should plan to read the offset value as a part of the timing interface to obtain UTC. The GPS week number is in reference to a base week (Week #0), starting January 6, 1980.

The current GPS UTC offset is contained within the almanac transmitted by the GPS system. The ACE II GPS must have a complete almanac before the offset data is valid.

3.5.1 Effect of GPS Week Number Roll-over (WNRO)

At 0000 hours Greenwich Mean Time (GMT) on 21/22 August 1999, the GPS Week Number will roll-over from 1023 to zero. Trimble receivers have numerous built-in protections to prevent this from being a catastrophic event. Systems may benefit however, from extra care with the first power-up after WNRO. For further information, consult the Y2K/WNRO website at www.trimble.com.



Note – GPS Week Numbers system, as defined by the ICD200 GPS Specification, occupy a range from zero to 1023. The Week Number Roll Over (WNRO) occurs every 1024 weeks, or approximately every 19 years 8 months. August 1999 is the first roll-over for the GPS system since the beginning of GPS time on 06 January 1980.

3.5.2 ACE II GPS/Palisade Family Firmware Version 7.xx Software Modifications

The ACE II GPS receiver has been designed to handle WNRO and there are no problems with either dates or the first fix after WNRO through the year 2015.



Caution – Trimble OEM GPS receivers have reported the true GPS Week Number in TSIP messages 0x41 and 0x8F-20 as a number between 0 and 1023. The ACE II GPS outputs the Extended GPS Week Number as the absolute number of weeks since the beginning of GPS time or 06 January 1980. If the true GPS Week Number is desired, the system developer should ignore the extra MSBs of the Extended GPS Week Number and use only the 10 LSBs.

3.6 Differential GPS

The ACE II GPS module can use differential corrections to compute a Differential GPS position (DGPS). DGPS can provide position accuracy of 2 meters (1 sigma).

RTCM SC-104, the industry standard format for differential corrections, is available from most DGPS reference stations, Coast Guard beacon transmissions, and commercial DGPS subscription services. The ACE II GPS is fully compatible with RTCM SC-104 Version 2.1. The ACE II GPS is factory configured to accept RTCM SC-104 correction data over Port 2 (J4, pin 7) at 4800 baud, 8 data bits, 1 stop bit and no parity. The DGPS operating mode is set to Automatic which means that the receiver will provide differential GPS solutions when valid correction data is available and will output standard GPS solutions when no valid correction data is available.

No setup is required to use RTCM SC-104 differential corrections, however, you may need to reconfigure the serial port characteristics (baud rate, data bits, stop bits and parity) to match the characteristics of your RTCM SC-104 data source using the TSIP packet 0xBC. See Appendix A for more information on this message. Table 3-1 summarizes the default characteristics for the ACE II GPS serial ports.

Alternatively, you may use Trimble's TSIP packets 60h and 61h to apply differential corrections through the ACE II GPS Port 1 (J3, pin 5). These packets can be interleaved with the TSIP command stream. Packets 60h and 61h are useful in applications which require the use of a single communications channel between the ACE II GPS and the system. Note that using these messages requires you to reformat the RTCM SC-104 differential correction data into the 60h/61h message format. See Appendix A for more information on these messages.

3.7 Configuring the ACE II GPS Receiver Protocols

It is good practice to store the ACE II GPS receiver configuration in non-volatile memory (EEPROM) rather than relying on battery-backed memory. This ensures the availability of the receiver configuration if back-up battery power is accidentally lost.

The configuration process is comprised of three steps. Detailed instructions are provided below.

1. Configure the receiver port PORT1 to TSIP input/output, as described in Section 3.7.1, *Re-configuring PORT1*.
2. Enter a series of configuration commands as described in Section 3.7.2, *Entering the Configuration*.
3. Return the receiver port to the original setting (if necessary); and issue a “save configuration command”, as described in Section 3.7.3, *Saving the Configuration*.

3.7.1 Re-configuring PORT1

If the PORT1 protocol is currently set to TSIP input/output, the port does not need to be re-configured, and you can proceed to Section 3.7.2, *Entering the Configuration*. Otherwise, reconfigure PORT1 as described below.

Depending on the current receiver configuration, select from the following three options to set the receiver PORT1 protocol to TSIP input/output.

1. If the PORT1 protocol is TSIP input but not TSIP output, re-configure PORT1 to TSIP input/output using the TSIP 0xBC command.
2. If the PORT1 input protocol is TAIP, apply an “>SPR...” command to change the PORT1 protocol to TSIP input/output temporarily. This may be done with TSIPCHAT. Use the ‘l’ keystroke and type in the following command at the prompt: “>SPR;TSIP=TF;TAIP=FF;NMEA=FO;RTCM=FI<”.
3. If the PORT1 input protocol is RTCM or none, but will eventually be changed to the TAIP or TSIP input protocol, first change the PORT1 protocol by sending a TAIP SPR command or TSIP 0xBC command through PORT2.



Note – At least one of the ports must be configured to either the TSIP or the TAIP input protocol at all times.

3.7.2 Entering the Configuration

The DOS program TSIPCHAT is used to configure the receiver to the desired settings. Table 3-2 lists the TSIPCHAT configuration commands. A complete description of these individual parameters is provided in Appendix A.

1. Start TSIPCHAT, with “TSIPCHAT -c1” if attached to PC serial port COM1, or with “TSIPCHAT -c2” if attached to PC serial port COM2.
2. If the PORT1 settings are not set to the TSIP default (9600 8-odd-1), use the keystroke ‘^i’ to set the PC serial port to match the PORT1 settings.
3. Send all desired configuration commands through PORT1, including the configuration for PORT2 (0xBC). If PORT1 is to be reconfigured to TAIP, or the baud rate, parity, etc. are to change, send the 0xBC command for PORT1 as the last command of the sequence.
4. Change the PC serial port settings to match the PORT1 settings. A short period of time may be required for the serial port communication to be re-acquired; two seconds is sufficient.

Table 3-2. TSIPCHAT Commands

TSIP Command ID	TSIPCHAT Keystroke	Description	TSIP Response ID
0x35	'O'	TSIP input/output formatting Superpacket output (on/off) Position format (LLA and/or ECEF) Precision (double or single) Altitude format (MSL or HAE) Timetag format (GPS or UTC) SNR format (AMU or C/N ₀) Automatic Pseudorange output	0x55
0x70	'I'	Position filter controls Position filter on/off Static filter on/off Altitude filter on/off	0x70
0x7A	'q'	NMEA message formats and schedule NMEA output messages NMEA output interval	0x7B
0xBB	'p'	GPS configuration parameters Operating dimension (2D, 3D, ...) DGPS mode Dynamics mode Elevation mask SNR mask DOP mask PDOP switch DGPS correction age	0xBB
0xBC	'U'	Serial port configuration Protocol: input, output Baud, data bits, parity, stop bits	0xBC
0x8E-15	'= t'	Output datum	0x8F-15
0x8E-19	'= f'	UTM output control	0x8F-19
0x8E-20	'= g'	Fixed point superfix control (default = on)	0x8F-20
0x8E-40	'= t'	TAIP configuration Report Mode Flags (command RM) Heartbeat message Heartbeat Top of Hour Offset Heartbeat Interval Vehicle ID Tag	0x8F-40

3.7.3 Saving the Configuration

Before writing the configuration to SEEPROM, verify that the receiver has been configured to the desired settings.



Warning – Record the serial port settings. If forgotten, they are difficult to recover.

1. If the PORT1 protocol is set to TAIP, send the TAIP command “SRTSAVE_CONFIG“. This can be done in TSIPCHAT using the keystroke ‘|’ and typing the string “>SRTSAVE_CONFIG<“ at the prompt.
2. If the PORT1 protocol is set to TSIP, use the TSIP command 0x8E-26 (TSIPCHAT ‘=’ then ‘s’).
3. Wait two seconds for the SEEPROM to be written.
4. Use a cold-start to verify that the procedure was successful. A cold-start is a power-cycle with no battery-backed memory. Use either the TSIP or TAIP protocol to initiate a cold-start and confirm that the receiver is initialized to the desired settings. In TSIP protocol, send the “clear RAM and restart” command, 0x1E-4B ‘(^k’ in TSIPCHAT). In TAIP protocol, send the TAIP cold-start command, “>SRTCOLD<“.

3.7.4 Returning to the Factory Settings

If the SEEPROM settings are incorrect, the board can be returned to the factory settings using the “factory reset” command.

1. If the input protocol is set to TAIP, use the TAIP entry command in TSIPCHAT, ‘|’, and type the string “>SRFACTORY<“.
2. If the input protocol is set to TSIP, use the TSIP factory reset command (TSIPCHAT, ‘^k’, clear RAM and SEEPROM).
3. Wait two seconds for the SEEPROM to be written.

4 Operation and Performance

This chapter describes the ACE II GPS satellite acquisition and tracking processes, performance characteristics and system architecture. This discussion assumes that you are familiar with the basic theory of the Global Positioning System. Before proceeding to the detailed discussion of the satellite acquisition and tracking process, please review the GPS satellite message description on the next page.

The ACE II GPS satellite acquisition and tracking algorithms can achieve a position solution without any initialization. The receiver automatically selects and tracks the best combination of satellites to compute position and velocity. As satellites move out of view, the ACE II GPS automatically acquires new satellites and includes them in the solution set as required.

4.1 GPS Satellite Message

Every GPS satellite transmits the Coarse/Acquisition (C/A) code and satellite data modulated onto the L1 carrier frequency (1575.42 MHz). The satellite data transmitted by each satellite includes a satellite almanac for the entire GPS system, its own satellite ephemeris and its own clock correction.

The satellite data is transmitted in 30-second frames. Each frame contains the clock correction and ephemeris for that specific satellite, and two pages of the 50-page GPS system almanac. The almanac is repeated every 12.5 minutes. The ephemeris is repeated every 30 seconds.

The system almanac contains information about each of the satellites in the constellation, ionospheric data, and special system messages. The GPS system almanac is updated weekly and is typically valid for months. The ephemeris contains detailed orbital information for a specific satellite. Ephemeris data changes hourly, but is valid for up to four hours. The GPS control segment updates the system almanac weekly and the ephemeris hourly through three ground-based control stations. During normal operation, the ACE II GPS module updates its ephemeris and almanac as needed.

The performance of a GPS receiver at power-on is determined largely by the availability and accuracy of the satellite ephemeris data and the availability of a GPS system almanac.

4.2 Satellite Acquisition and Time to First Fix

4.2.1 Cold-Start

The term “cold-start” describes the performance of a GPS receiver at power-on when no navigation data is available. “Cold” signifies that the receiver does not have a current almanac, satellite ephemeris, initial position, or time. The cold-start search algorithm applies to a ACE II GPS which has no memory of its previous session (i.e., is powered on without the memory backup circuit connected to a source of DC power). This is the “out of the box” condition of the GPS module as received from the factory.

In a cold-start condition the receiver automatically selects a set of eight satellites and dedicates an individual tracking channel to each satellite, to search the Doppler range frequency for each satellite in the set. If none of the eight selected satellites is acquired after a pre-determined period of time (time-out), the receiver will select a new search set of eight satellites and will repeat the process, until the first satellite is acquired. As satellites are acquired, the receiver automatically collects ephemeris and almanac data. The ACE II GPS uses the knowledge gained from acquiring a specific satellite to eliminate other satellites, those below the horizon, from the search set. This strategy speeds the acquisition of additional satellites required to achieve the first position fix.

The cold-start search sets are established to ensure that at least three satellites are acquired within the first two time-out periods. As soon as three satellites are found, the receiver will compute an initial position fix. The typical time to first fix is less than 2 minutes.

A complete system almanac is not required to achieve a first position fix. However, the availability and accuracy of the satellite ephemeris data and the availability of a GPS almanac can substantially shorten the time to first fix.



Note – When installed in the interface unit, the ACE II GPS receives back-up power from a lithium battery. This battery enables the ACE II GPS to always start from either a warm or hot start. To force a cold start, issue the 1E TSIP command ([Control] + [K]) in the TSIP chat program on the GPS toolkit diskette in the Starter Kit).

4.2.2 Warm Start

In a warm start condition, the receiver has been powered down for at least one hour but has a current almanac and an initial position and time stored in memory.

When connected to an external backup battery and power is applied, the ACE II GPS retains the almanac, approximate position, and time to aid in satellite acquisition and reduce the time to first fix. When an external back-up battery is not used, the TSIP protocol allows the almanac, an initial position, and time to be uploaded to the receiver via the serial port, to initiate a warm start.

During a warm start, the ACE II GPS identifies the satellites which are expected to be in view, given the system almanac, the initial position and the approximate time. The receiver calculates the elevation and expected Doppler shift for each satellite in this expected set and directs the eight tracking channels in a parallel search for these satellites.

The warm start time to first fix, when the receiver has been powered down for more than 60 minutes (i.e. the ephemeris data is old), is usually less than 45 seconds.

4.2.3 Garage Search Strategy

During a warm start search, the ACE II GPS knows which satellites to search for, based on the system almanac, the initial position (last known position) and the current time. In some cases, the receiver may not be able to acquire the expected satellite signals (e.g., a vehicle parked in a garage or a vessel in a covered berth). Trimble's patented "garage search" strategy, also known as a split search, is designed for such situations.

If the receiver does not acquire the expected set of satellites within 5 minutes of power-on, some of the eight tracking channels will continue to search for the expected satellites (warm search) while the remaining channels are directed in a cold start search. This strategy minimizes the time to first fix in cases where the stored almanac, position and time are invalid. The stored information is flushed from memory, if the cold start search proves effective and the warm search fails.

4.2.4 Hot Start

A hot start strategy applies when the ACE II GPS has been powered down for less than 60 minutes, and the almanac, position, ephemeris, and time are valid. The hot start search strategy is similar to a warm start, but since the ephemeris data in memory is considered current and valid, the acquisition time is typically less than 20 seconds.

4.3 Satellite Mask Settings

Once the ACE II GPS has acquired and locked onto a set of satellites, which pass the mask criteria listed in this section, and has obtained a valid ephemeris for each satellite, it will output regular position, velocity and time reports according to the protocol selected.

The default satellite masks observed by the ACE II GPS are listed in Table 4-1. These masks serve as the screening criteria for satellites used in fix computations and ensure that position solutions meet a minimum level of accuracy. The ACE II GPS will only output position, course, speed and time when a satellite set can be acquired which meets all of the mask criteria. The satellite masks can be adjusted in GPS receivers accepting the TSIP protocol. (See the section titled *Key Setup Parameters*, located in Appendix A.)

Table 4-1. Default Satellite Mask Settings

Mask	Setting
Elevation	5°
SNR	2
PDOP	12
PDOP Switch	5

4.3.1 Elevation Mask

Satellites below a 5° elevation are not used in the position solution. Although low elevation satellites can contribute to a lower/better PDOP, the signals from low elevation satellites are poorer quality, since they suffer greater tropospheric and ionospheric distortion than the signals from higher elevation satellites. These signals travel further through the ionospheric and tropospheric layers.

In addition, low elevation satellites can contribute to frequent constellation switches, since the signals from these satellites are more easily obscured by buildings and terrain. Constellation switches can cause noticeable jumps in the position output. Since worldwide GPS satellite coverage is generally excellent, it is not usually necessary to use satellites below a 5° elevation to improve GPS coverage time. In some applications, like urban environments, a higher mask may be warranted to minimize the frequency of constellation switches and the impact of reflected signals.

4.3.2 SNR Mask

Although the ACE II GPS is capable of tracking signals with SNRs as low as 0, the default SNR mask is set to 2 to eliminate poor quality signals from the fix computation and minimize constellation switching. Low SNR values may result from:

- Low Elevation Satellites
- Partially Obscured Signals (e.g. Dense Foliage)
- Multi-Reflected Signals (Multi-Path)

The distortion of signals and the frequent constellation switches associated with low-elevation satellites were discussed above. In mobile applications, the attenuation of signals by foliage is typically a temporary condition. Since the ACE II GPS can maintain lock on signals with SNRs as low as 0, it offers excellent performance when traveling through heavy foliage.

Multi-reflected signals, also known as Multi-path, can degrade the position solution. Multi-path is most commonly found in urban environments with many tall buildings and a preponderance of mirrored glass, which is popular in modern architecture. Multi-reflected signals tend to be weak (low SNR value), since each reflection attenuates the signal. By setting the SNR mask to 2 or higher, the impact of multi-reflected signals is minimized.

4.3.3 DOP Mask

Position Dilution of Precision (DOP) is a measure of the error caused by the geometric relationship of the satellites used in the position solution. Satellite sets which are tightly clustered or aligned in the sky will have a high DOP and will contribute to a lower position accuracy. For most applications, a DOP mask of 10 offers a satisfactory trade-off between accuracy and GPS coverage time. With world-wide GPS coverage now available, the DOP mask can be lowered even further for many applications without sacrificing coverage. For differential GPS applications, DOP related error can be the major contributor to position error. For differential GPS applications requiring the highest level of accuracy, the DOP mask should be set to 7 or below.

4.3.4 PDOP Switch

The default positioning mode for the ACE II GPS is Automatic. In this mode, the receiver attempts to generate a 3-dimensional (3D) position solution, when four or more satellites meeting the mask criteria are visible. If such a satellite set cannot be found, the receiver will automatically switch to 2-dimensional (2D) mode. The PDOP switch establishes the trade-off between 3D positioning and PDOP. With the PDOP Switch set to 6, the receiver will compute a 2D position with a HDOP below 6 rather than a 3D position with a PDOP greater than 6, even when four or more satellites are visible.



Note – PDOP Switch is only used in Auto mode.

4.4 Standard Operating Modes

The tracking mode controls the allocation of the receiver's tracking channels and the method used for computing position fixes. The output of GPS data is controlled by two operating modes:

- Fix Modes (2D, 3D, or Automatic)
- Differential GPS Mode (On, Off, or Auto)

Each of these operating modes is described below.

4.4.1 Fix Modes

The ACE II GPS offers three positioning modes: 2D Manual, 3D Manual, and Automatic 2D/3D. Automatic 2D/3D is the default mode for the ACE II GPS. The positioning mode can be modified in receivers accepting TSIP commands. See Appendix A for more information on the TSIP protocol.

2D Manual

In 2D Manual mode, the ACE II GPS will only generate 2-dimensional (2D) position solutions (latitude and longitude only), regardless of the number of visible satellites. If the altitude is not entered, the receiver uses zero as the default altitude. The greater the deviation between the actual and default altitudes, the greater the error in the 2D position. For TSIP applications, enter local altitude in MSL/HAE via TSIP packet 2AH (see Appendix A).



Note – 2D Manual mode is not recommended for differential GPS applications since any deviation in altitude will cause a significant error in the latitude and longitude. Only use the 2D Manual mode for flat land or marine applications where the elevation is known or constant. For DGPS applications, the 3D Manual mode is the recommended positioning mode for the highest level of accuracy.

3D Manual

In 3D Manual mode, the ACE II GPS will only generate 3-dimensional (3D) position solutions (latitude, longitude, and altitude). A 3D solution requires at least four visible satellites which pass the mask criteria. If less than four conforming satellites are visible, the ACE II GPS will suspend position data outputs. 3D Manual mode is recommended for differential GPS applications requiring the highest level of accuracy.

2D/3D Automatic

The default operating mode for the ACE II GPS is 2D/3D Automatic. In this mode, the ACE II GPS attempts to generate a 3-dimensional (3D) position solution, if four or more satellites meeting the mask criteria are visible. If only three satellites are visible which meet the mask criteria, the ACE II GPS will automatically switch to 2-dimensional (2D) mode and will use the last calculated altitude, if available, or the default altitude in the position solution. In 2D/3D Automatic mode, the PDOP switch is active.

4.5 Differential GPS Operating Modes

The default mode for the ACE II GPS is DGPS Automatic. The ACE II GPS supports three DGPS Modes: On, Off, and Automatic, and the mode may be changed by issuing the appropriate TSIP command. See Appendix A for information on TSIP commands. The three DGPS operating modes are described below.

4.5.1 DGPS On

When DGPS On is selected, the ACE II GPS will only provide differential GPS solutions. If the source of correction data is interrupted or becomes invalid, the ACE II GPS will suspend all output of position, course and speed data. When a valid source of correction data is restored, the ACE II GPS will resume outputting corrected data.

4.5.2 DGPS Off

When DGPS Off is selected, the ACE II GPS will not provide differential GPS solutions, even if a valid source of correction data is supplied. In this mode, the receiver will only supply standard GPS data.

4.5.3 DGPS Automatic

DGPS Automatic is the default operating mode for the ACE II GPS. In this mode, the ACE II GPS will provide differential GPS solutions when valid correction data is available. If a set of differentially correctable satellites cannot be found which meets the satellite mask settings, the receiver will transition to output standard GPS solutions. The ACE II GPS automatically switches between DGPS and standard GPS based on the availability of valid correction data.

4.5.4 Differential GPS Operation

The ACE II GPS is capable of accepting and decoding RTCM SC-104 data. RTCM SC-104 is an industry standard protocol for differential correction data. The ACE II GPS is configured to accept RTCM SC-104 correction data over Port 2 (J3, pin 7). Alternatively, you can use TSIP packets 60 and 61 or the TAIP and DD messages to input differential corrections through the primary serial port (J4, pin 5).

4.6 Position Accuracy

GPS position accuracy is degraded by atmospheric distortion, satellite and receiver clock errors, and Selective Availability (SA). Effective models for atmospheric distortion of satellite signals have been developed to minimize the impact of tropospheric and ionospheric effects. The impact of satellite clock errors is minimized by incorporating the clock corrections transmitted by each satellite used in the position solution. SA is the most significant contributor to position error and cannot be effectively combated except with differential GPS.

4.6.1 Selective Availability (SA)

The U.S. Department of Defense, through a program called Selective Availability, intentionally degrades GPS accuracy for civilian users. The SA program creates position errors by modifying the apparent position of each satellite and introducing random dither into each satellite's clock.

In extreme cases all sources of error (natural, PDOP, and SA) can combine to produce large position errors. The DOD's definition of accuracy under SA is 100 meters 2 dRMS (horizontal 2 dimensional, 95% of the time). In April 1996, the U.S. government approved plans for disabling SA.

4.6.2 Differential GPS (DGPS)

Differential GPS is an effective technique for overcoming the effects of SA and other sources of position error. DGPS relies on GPS error corrections transmitted by a reference station placed at a known location. The reference station compares its GPS position solution to its precisely surveyed position and calculates the error in each satellite's range measurement. The industry standard protocol for GPS correction data is RTCM SC-104.

The GPS corrections are broadcast to mobile GPS receivers in neighboring areas. The mobile receivers incorporate the GPS corrections in their position solution to achieve excellent accuracy. For marine applications, corrections are typically modulated on marine radio beacon broadcasts. For land-based applications, the correction data can be transmitted over FM sub-carrier, cellular telephone or dedicated UHF or VHF radio links.

DGPS can reduce position error to under 5 meters, 95% of the time under steady state conditions. The DGPS accuracy is highly dependent on the quality and age of the differential corrections and the proximity of the mobile receiver to the reference site.

4.7 Coordinate Systems

Once the ACE II GPS achieves its first fix, it is ready to commence output of position, velocity, and time information.

This information is output over serial communication channel in either the TSIP, TAIP, or NMEA protocol, as determined by the settings of the receiver. These protocols are defined in the following Appendices:

- TSIP - Appendix A, Trimble Standard Interface Protocol (TSIP)
- TAIP - Appendix A, Trimble ASCII Interface Protocol (TAIP)
- NMEA - Appendix E, NMEA 0183

To change from one protocol to another, please see “Configuring your Receiver” in Appendix A, Trimble Standard Interface Protocol (TSIP).

4.7.1 TSIP Coordinate Systems

TSIP has the widest choice of coordinate systems. The output format is chosen by TSIP command 0x35. The output formats include the following:

- LLA position — Latitude, longitude, altitude (LLA) according to the WGS ellipsoid or one of over a hundred other datums. See Appendix A, Table A-86 for a list of available datums. Altitude can be chosen to be height above ellipsoid (HAE) or height above mean sea level (MSL).
- ENU velocity — ENU velocity is the velocity in East, North, and Up coordinates. These coordinates are easily converted to speed and heading.
- ECEF position and velocity — ECEF position and velocity is Earth-Centered, Earth-Fixed frame is a Cartesian coordinate frame with its center at the earth's center, the z-axis through the North Pole, and the x-axis through longitude 0 degrees, latitude 0 degrees. Velocity is reported relative to the same axes.
- UTM — Universal Transverse Mercator (UTM) is a mapping coordinate system used by many government agencies.

There are also two time coordinate systems:

- GPS time — GPS time is determined by an ensemble of atomic clocks operated by the Department of Defense (DOD).
- UTC time — UTC time is the world standard maintained by an ensemble of atomic clocks operated by government organizations around the world.

GPS time is steered relative to Universal Coordinated Time (UTC). GPS does not recognize leap seconds resulting in a situation where GPS time is currently 13 seconds ahead of UTC time. Time tags for most output messages can be in either UTC time or GPS time, as chosen by TSIP command 0x35.

4.7.2 NMEA 0183

The NMEA 0183 protocol only supports LLA format and UTC time. Velocity is always described as horizontal speed and heading; vertical speed is not output.

4.7.3 TAIP

The TAIP protocol only supports LLA position output. Timetags are GPS, except for the TM time mark message.

4.8 Performance Characteristics

4.8.1 Update Rate

The ACE II GPS computes and outputs position solutions once per second, on the second. NMEA outputs can be scheduled at a slower rate using TSIP command 7Ah. Refer to Appendix A.

4.8.2 Dynamic Limits

The dynamic operating limits for the ACE II GPS are listed below. These operating limits assume that the GPS module is correctly embedded and that the overall system is designed to operate under the same dynamic conditions.

Table 4-2. ACE II GPS Operating Limits

Operation	Limit
Acceleration	4 g (39.2 m/s ²)
Jerk	20 m/s ³
Speed	500 m/s
Altitude	18,000 m

4.8.3 Re-Acquisition

Re-acquisition time for a momentary signal blockages is typically under 2 seconds.

When a satellite signal is momentarily interrupted during normal operation, the receiver continues to search for the lost signal at the satellite's last known Doppler frequency. If the signal is available again within 15 seconds, the receiver will normally re-establish track within two seconds. If the lost signal is not re-acquired within 15 seconds, the receiver initiates a broader frequency search. The receiver will continue to search for the satellite until it falls below the elevation mask.

4.9 GPS Timing

In many timing applications, such as time/frequency standards, site synchronization systems and event measurement systems, GPS receivers are used to discipline local oscillators.

The GPS constellation consists of 24 orbiting satellites. Each GPS satellite contains a highly-stable atomic (Cesium) clock, which is continuously monitored and corrected by the GPS control segment. Consequently, the GPS constellation can be considered a set of 24 orbiting clocks with worldwide 24-hour coverage.

GPS receivers use the signals from these GPS “clocks” to correct its internal clock, which is not as stable or accurate as the GPS atomic clocks. GPS receivers like the ACE II GPS output a highly accurate timing pulse (PPS) generated by its internal clock, which is constantly corrected using the GPS clocks. This timing pulse is synchronized to UTC within ± 500 ns.

In addition to serving as a highly accurate stand-alone time source, GPS receivers are used to synchronize distant clocks in communication or data networks. This synchronization is possible since all GPS satellite clocks are corrected to a common master clock. Therefore, the relative clock error is the same, regardless of which satellite or satellites are used. For timing applications requiring a “common clock”, GPS is the ideal solution.

GPS time accuracy is bounded by the same major source of error affecting position accuracy, Selective Availability. The position and time errors are related by the speed of light. Therefore, a position error of 100 meters corresponds to a time error of approximately 333 ns. The hardware and software implementation affects the GPS receiver's PPS accuracy level. The receiver's clocking rate determines the PPS steering resolution.

The ACE II GPS clocking rate is 3.126 MHz. This rate corresponds to a steering resolution of ± 160 ns. Software techniques such as over-determined clock algorithm can achieve PPS accuracy better than Selective Availability because more satellites are used to give a higher timing accuracy.

4.9.1 Serial Time Output

Both the TSIP, TAIP, and NMEA protocols include time messages. Refer to Report Packet 41 in Appendix A or the ZDA descriptions in Appendix D for a description of the time reports for each protocol and the TAIP TM message.



Note – GPS time differs from UTC (Universal Coordinated Time) by a variable, integer number of seconds $UTC = (GPS \text{ time}) - (GPS \text{ UTC offset})$.

As of January 1999, the GPS UTC offset was 13 seconds. The offset has historically increased by 1 second about every 18 months. System designers should plan to read the offset value as a part of the timing interface to obtain UTC. The GPS week number is in reference to a base week (Week #0), starting January 6, 1980.

4.9.2 Timing Pulse Output (PPS)

A pulse-per-second (PPS), ten microsecond wide pulse is available on the ACE II GPS 8-pin interface connector. The pulse is sent once per second and the rising edge of the pulse is synchronized with UTC. The pulse shape is affected by the distributed capacitance of the attached cabling and input circuit. The rising edge is typically less than 20 ns wide. The falling edge should never be used for timing applications.



Note – The PPS signal output by the ACE II GPS is a CMOS/TTL level signal. If this signal must be furnished to a remote location, the system designer should provide an RS-422 driver for the timing pulse.

When the ACE II GPS is installed on the interface motherboard (supplied in the Starter Kit), the PPS signal is connected to an open collector circuit and the polarity of the signal is inverted.

4.10 System Architecture

The ACE II GPS module (see Figure 4-1) uses eight processing channels operating on the L1 frequency of 1575.42 MHz and using the coarse acquisition (C/A) code. The module uses custom integrated circuitry designed by Trimble to track the GPS satellite signals. These ICs also contain support circuitry to the navigation processor. An integrated 32-bit microprocessor is used for tracking, computing a position, and performing the I/O operations.

The module receives the GPS satellite signals through the antenna feed line connector, amplifies the signals, and then passes them to the RF down converter. A highly stable crystal reference oscillator operating at 12.504 MHz is used by the down converter to produce the signals used by the 8-channel signal processor. The 8-channel signal processor tracks the GPS satellite signals and extracts the carrier code information as well as the navigation data at 50 bits per second.

Operation of the tracking channels is controlled by the navigation processor. The tracking channels are used to track the highest eight satellites above the horizon. The navigation processor will then use the optimum satellite combination to compute a position. The navigation processor also manages the ephemeris and almanac data for all of the satellites, and performs the data I/O.

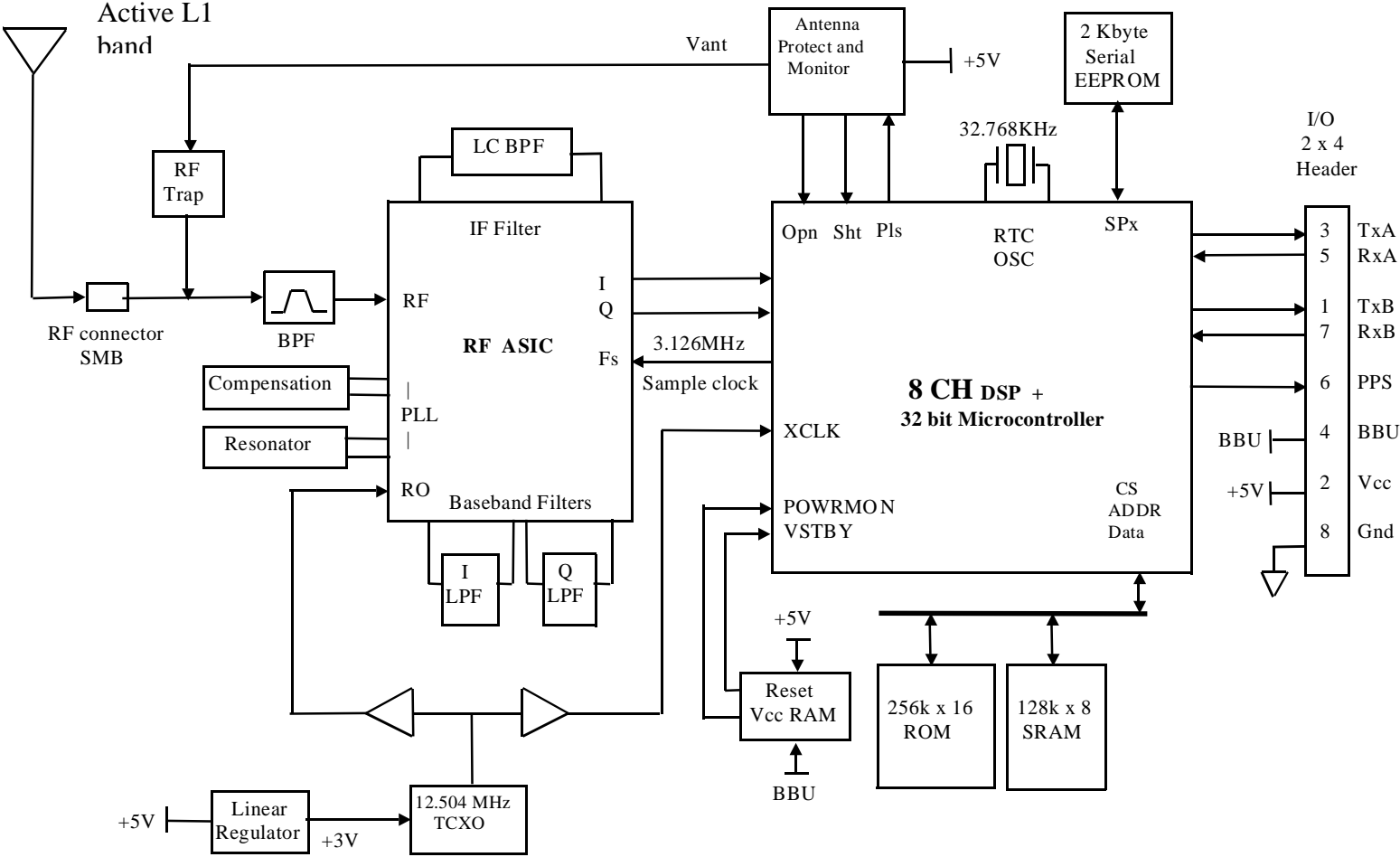

Figure 4-1. ACE II GPS Block Diagram

A Trimble Standard Interface Protocol

The Trimble Standard Interface Protocol (TSIP) provides the system designer with over 75 commands that may be used to configure a GPS receiver for optimum performance in a variety of applications. TSIP enables the system designer to customize the configuration of a GPS module to meet the requirements of a specific application.

This appendix provides the information needed to make judicious use of the powerful features TSIP has to offer, to greatly enhance overall system performance and to reduce the total development time. The reference tables beginning on Page A-2 will help you determine which packets apply to your application. For those applications requiring customizing, see Page A-3. For a detailed description of the key setup parameters see Page A-13. Application guidelines are provided for each TSIP Command Packet, beginning on Page A-17.

A.1 Interface Scope

The Trimble Standard Interface Protocol is used in Trimble 6-channel and 8-channel receiver designs. The protocol was originally created for the Trimble Advanced Navigation Sensor (TANS) and is colloquially known as the TANS protocol even though the protocol applies to many other devices.

The ACE II GPS module has two independently configurable serial I/O communication ports. Port 1 is a bi-directional control and data port utilizing a Trimble Standard Interface Protocol (TSIP) or Trimble ASCII Interface Protocol (TAIP). Port 2 is a bi-directional port used to receive differential GPS (DGPS) corrections in the industry standard RTCM-104 format and for output of industry standard ASCII NMEA sentences. Port 1 can also be configured to TAIP I/O using TSIP commands. The dual data I/O port characteristics and other options are user programmable and stored in non-volatile memory.

The TSIP protocol is based on the transmission of packets of information between the user equipment and the unit. Each packet includes an identification code that identifies the meaning and format of the data that follows. Each packet begins and ends with control characters.

This document describes in detail the format of the transmitted data, the packet identification codes, and all available information over the output channel to allow the user to choose the data required for his particular application. As will be discussed, the receiver transmits some of the information (position and velocity solutions, etc.) automatically when it is available, while other information is transmitted only on request. Additional packets may be defined for particular products and these will be covered in the specifications for those products as necessary.

The TSIPCHAT utility, part of the GPS Tool Kit, is designed to exercise many of the TSIP packets. The GPSSK Utility, part of the GPS Tool Kit, is designed to exercise many of the TSIP messages

A.2 Automatic Output Packets

The ACE II GPS receiver module is configured to automatically output the following packets. For minimal system implementations, these output packets provide all of the information required for operation including time, position, velocity, and receiver and satellite status and health. Position and velocity are reported using one or more of the packets listed below, depending on the selected I/O options. While there are other packets automatically output, the following packets provide the information most commonly used. No input packets are required.

Table A-1. Automatic Output Packets

Output Packet ID	Description	Reporting Interval
0x40	Almanac	When decoded
0x41	GPS time	With position fix every 150 seconds No position fix every 15 seconds
0x42, 0x83, 0x4A, 0x84, 0x43, 0x56, 0x8F-17, 0x8F-18, 0x8F-20	position (choose packet with I/O options)	1 second
0x43, 0x56, 0x8F-20	velocity (choose packet with I/O options)	1 second
0x46	health of receiver	30 seconds (Note 1.)
0x4B	machinecode/status (includes antenna fault detect)	30 seconds (Note 1.)
0x5B	Ephemeris status	When decoded
0x6D	all-in-view satellite selection	30 second (Note 1.)
0x82	DGPS position fix mode (only in DGPS mode)	30 second (Note 1.)
0x5A, 0x6F	Pseudorange	1 second

Note 1. – See page A-18 for a detailed description of the key receiver setup parameters.

A.3 Customizing Receiver Operations

For information on customizing receiver operations, see page 3-7, *Configuring the ACE II GPS Receiver Protocols*.

A.4 Automatic Position and Velocity Reports

The receiver automatically outputs position and velocity reports at set intervals. Automatic report packets are controlled by Packet 35. Setting the control bits as indicated in the table below allows you to control which position and velocity packets are output.

Table A-2. Automatic Position and Velocity Reports Control Setting Bits

Packet ID	Description	Byte 0				Byte 1	
		Bit 0	Bit 1	Bit 4	Bit 5	Bit 0	Bit 1
0x42	single precision XYZ position	1		0			
0x83	double-precision XYZ position	1		1			
0x4A	single-precision LLA position		1	0			
0x84	double-precision LLA position		1	1			
0x43	velocity fix (XYZ, ECEF)					1	
0x56	velocity fix (ENU)						1
0x8F-17	single precision UTM			0	1		
0x8F-18	double precision UTM			1	1		
0x8F-20	LLA & ENU				1		

A.5 Initialization Packets to Speed Start-up

If you are not supplying the receiver with battery power when main power is off, you can still "warm-start" the receiver by sending the following commands after the receiver has completed its internal initialization and has sent Packet 82 (see Table A-5).

Table A-3. Receiver Initialization Commands

Byte	Input		Description
		Subcode	
0x2B			initial position
0x2E			initial time
0x38		02	almanac (for each SV)
0x38		03	almanac health
0x38		04	ionosphere page
0x38		05	UTC correction

A.6 Packets Output at Power-Up

The following table lists the messages output by the receiver at power-up. After completing its self-diagnostics, the receiver automatically outputs a series of packets which indicate the initial operating condition of the receiver. Messages are output in the following order. After Packet 82 is output, the sequence is complete and the receiver is ready to accept commands.

Table A-4. Output Packets at Power-up

Output ID	Description	Notes
0x46	Receiver health	--
0x4B	Machine code/status	--
0x4A	Position output	As chosen, see Table A-2
0x56	Velocity fix	As chosen, see Table A-2
0x41	GPS time	This Packet is only output if GPS time is available.
0x82	DGPS position fix mode	--

A.7 Differential GPS Packets

For differential GPS applications you may need to implement the following TSIP control commands.

Table A-5. Differential GPS Packet TSIP Control Commands (DGPS)

Input ID	Description	Output ID
0x60	differential GPS corrections (types 1 and 9)	--
0x61	differential GPS corrections (type 2)	--
0x65	differential correction data request	0x85
0xBB	differential Auto or Manual operating mode.	0xBB
0xBB	Maximum age that differential corrections will be used	0xBB
0xBC	port configuration	0xBC

A.8 Timing Packets

If you are using the ACE II GPS as a timing system, you may need to implement the following TSIP control commands.

Table A-6. Timing Packet TSIP Control Commands

Input ID	Description	Output ID
0x21	get the current GPS time	0x41
0x38-05	request UTC parameters	0x58-05

A.9 Satellite Data Packets

The following packets contain a variety of GPS satellite data.

Table A-7. Satellite Date Packet Data I/O Descriptions

Input ID	Description	Output ID
0x27	request signal levels	0x47
0x28	request GPS system message	0x48
0x38	request/load satellite system data	0x58
0x39	set/request satellite disable or ignore health	0x59
0x3A/auto	request last raw measurement	0x5A
0x3C	request tracking status	0x5C
auto	synchronized measurement packet	0x6F

A.10 Background Packets

The receiver automatically outputs a set of packets that the user may want to monitor for changes in receiver operations. These messages are output at the rates indicated in the table below.

Table A-8. Background Packet Output Messages

Output ID	Description	Notes
0x40	almanac	As new almanacs are decoded. See 0x58 message for more information.
0x41	GPS time	If the receiver's GPS clock is set and the receiver is not outputting positions, time is output approximately every 15 seconds. After tracking occurs this packet ever 150 seconds
0x46, 0x4B	receiver health messages	Receiver health messages are output every 30 seconds.
0x5B	ephemeris status	As new ephemerides are decoded. See 0x58 message for more information.
0x6D	mode packets	Mode packets are output every 30 seconds.

A.11 Backwards Incompatibility of ACE II GPS Packets with Previous Versions of CM3 and SVEeSix

Several new TSIP command packets have been made available with the release of the ACE II GPS receiver module, and some existing packets have been modified or are no longer supported. Table A-10 identifies the backwards compatibility of auto-output packets. Table A-11 identifies the backwards compatibility of the TSIP command packets. Unless otherwise noted, the commands and their corresponding output packets are still supported in the firmware.

Table A-9. Supported Auto-Output Packet Command Backward Incompatibility

Old Packet	New Packet
0x44	0x6D
0x5E	
0x8F-01, 0x8F-02	0x8F-20

Table A-10. TSIP Command Backward Incompatibility

Old Packet		New Packet		Notes
Input	Output	Input	Output	
0x20	0x40	0x38-02	0x58-02	
0x22		0xBB	0xBB	
0x29	0x49	0x38-03	0x58-03	
0x2A	none	0x2A	0x4A (9 byte)	
0x2C	0x4C	0xBB	0xBB	
0x2F	0x4F	0x38-05	0x58-05	
0x34	0x44, 0x6D			0x34 not supported
0x36				0x36 not supported
0x3B	0x5B	0x38-06	0x58-06	
0x3D	0x3D	0xBC	0xBC	
0x3E	0x5E			0x3E not supported
0x62 (set mode)	0x82	0xBB	0xBB	use 0x62 for query of current mode
0x75	0x76	0xBB	0xBB	0x75 not properly supported
0x77	0x78	0xBB	0xBB	
0x79	0x79			0x79 not supported
0x8E-01, 0x8E-02	0x8F-01, 0x8F-02	0x8E-20	0x8F-20	0x8E-01 and 0x8E-02 not supported
0x8E-03	0x8F-03	0xBB	0xBB	
0x8E-14	0x8F-14	0x8E-15	0x8F-15	

A.12 Recommended TSIP Packets

Table A-11. Recommended TSIP Packet Data

Function	Description	Input	Output
Protocol and port setup	set/query port configuration	0xBC	0xBC
	set/query NMEA configuration	0x7A	0x7B
	set/query I/O options (autoreport and format options)	0x35	0x55
	packet output control	0x6E	0x6E
	Set TAIP protocol	0x8E-40	0x8F-40
Receiver settings	query software version	0x1F	0x45
	set/query datum values	0x8E-15	0x8F-15
	query receiver ID & error status	0x26	0x4B, 0x46
	set/query satellite flags	0x39	0x59
	set/query receiver configuration	0xBB	0xBB
	set altitude for 2D mode	0x2A	0x4A
disable PV/altitude filters	0x70	0x70	
Initialization	full reset (clear battery backup and/or non-volatile settings)	0x1E	--
	soft reset	0x25	--
	set GPS time	0x2E	0x4E
	set exact LLA	0x32	--
	set approx. XYZ	0x23	--
	set approx. LLA	0x2B	--
	set exact XYZ	0x31	--
Navigation	GPS time	0x21	0x41
	position & velocity (superpacket)	0x8E-20 or 0x37 or auto	0x8F-20
	double-precision LLA	0x37/auto	0x84
	double-precision XYZ	0x37/auto	0x83
	ENU velocity	0x37/auto	0x56
	XYZ velocity	0x37/auto	0x43

Table A-11. Recommended TSIP Packet Data (Continued)

Satellite and tracking information	query receiver state (health)	0x26	0x46, 0x4B
	query current satellite selection	0x24	0x6D
	query signal levels	0x27	0x47
	query satellite information (azimuth, elevation, etc.)	0x3C	0x5C
	synchronized measurement packet	auto	0x6F
	set/query positioning mode (2D v. 3D)	0xBB	0xBB
DGPS	query DGPS corrections	0x65	0x85
	query DGPS operating mode & status	0x62	0x82
	load DGPS Type 1 correction	0x60	--
	load DGPS Type 2 correction	0x61	--
GPS system	query/load GPS system data	0x38	0x58
	GPS system message	0x28	0x48

A.13 Command Packets Sent to the Receiver

The table below summarizes the command packets sent to the receiver. The table includes the input Packet ID, a short description of each packet, and the associated response packet. In some cases, the response packets depend on user-selected options. These selections are covered in the packet descriptions in Section A-18.

Table A-12. Standard TSIP Command Packets

Input ID	CM3	ACE	Packet Description	Output ID
0x1D	X	X	Clear Oscillator Offset	--
0x1E	X	X	Clear Battery Backup	(Note 1)
0x1F	X	X	Software Version	0x45
0x20	X	X	Almanac	0x40
0x21	X	X	Current Time	0x41
0x22	X	X	Mode Select (3D, 2D, Auto)	0x44 or 0x 6D (Note 2)
0x23	X	X	Initial Position (XYZ ECEF)	--
0x24	X	X	Request receiver position fix mod	0x6D
0x25	X	X	Soft reset / Self test	(Note 1)
0x26	X	X	Receiver Health	0x46, 0x4B
0x27	X	X	Signal Levels	0x47 (Note 2)
0x28	X	X	GPS System Message	0x48
0x29	X	X	Almanac health page	0x49
0x2A	X	X	Altitude for 2D mode	--
0x2B	X	X	Initial Position (Lat, Long, Alt)	--
0x2C	X	X	Operating parameters	0x4C
0x2D	X	X	Show Oscillator Offset	0x4D
0x2E	X	X	Set GPS time	0x4E
0x2F	X	X	UTC parameters	0x4F
0x31	X	X	Accurate Initial position (XYZ ECEF)	--
0x32	X	X	Accurate Initial position	--
0x34	X		Satellite # for 1-sat mode	--
0x35	X	X	I/O options	0x55
0x36	X		Velocity aiding of acquisition	--
0x37	X	X	Status and values of last position and velocity	0x57 (Note 1)
0x38	X	X	Load satellite system data	0x58
0x39	X	X	Satellite disabled	0x59 (Note 3)

Table A-12. Standard TSIP Command Packets

Input ID	CM3	ACE	Packet Description	Output ID
0x3A	X	X	Last raw measurement	0x5A (Note 3)
0x3B	X	X	Satellite ephemeris status	0x5B
0x3C	X	X	Tracking Status	0x5C (Note 2)
0x3D	X	X	Main port configuration	0x3D
0x3E	X		Additional fix parameters	0x5E
0x60	X	X	Type 1 differential GPS position fix mode	--
0x61	X	X	Set differential correction	--
0x62	X	X	Set / Request differential GPS position fix mode	0x82
0x65	X	X	Differential correction status	0x85 (Note 2)
0x6E		X	Synchronized measurement parameters	0x6E
0x70		X	Filter configuration	0x70
0x71	X	X	Position filter parameters	0x72
0x73	X	X	Height filter control	0x74
0x75	X		Best 4 / High 6 (Over-determined) control	0x76
0x77	X	X	Maximum rate of DGPS corrections	0x78
0x7A		X	Set / Request NMEA output configuration	0x7B
0xBB		X	Set receiver configuration	0xBB
0xBC		X	Set port configuration	0xBC



Note 1. – Output is determined by packet 35 settings.

Note 2. – No response sent if data is not available.

Note 3. – Not all packet 0x39 operations have a response.

Table A-13. TSIP Super Command Packets

Input ID	CM3	ACE	Packet Description	Output ID
0x8E 03	X	X	auxiliary port configuration	0x8F-03
0x8E 14	X	X	datum	0x8F-14
0x8E 15	X	X	datum	0x8F-15
0x8E 19	X	X	UTM Enabled / Disabled	0x8F-19
0x8E 20	X	X	last fix with extra information (fixed point)	0x8F-20
0x8E 26		X	SEEPROM write status	0x8F-26
0x8E 40		X	TAIP configuration	0x8F-40

A.14 Report Packets Sent by the GPS Receiver to the User

The table below summarizes the packets output by the receiver. The table includes the output Packet ID, a short description of each packet, and the associated input packet. In some cases, the response packets depend on user-selected options. These selections are covered in the packet descriptions beginning on page A-23.

Table A-14. Standard TSIP Report Packets

Output ID	Packet Description	Input ID
0x41	GPS time	0x21, auto
0x42	single-precision XYZ position	0x37, auto, power-up
0x43	velocity fix (XYZ ECEF)	0x37, auto
0x45	software version information	0x1F, power-up
0x46	health of Receiver	0x26, auto, power-up
0x47	signal level for all satellites	0x27
0x48	GPS system message	0x28
0x4A	single-precision LLA position	0x37, auto
0x4B	machine code/status	0x26, auto, power-up
0x4D	oscillator offset	0x2D
0x4E	response to set GPS time	0x2E
0x55	I/O options	0x35
0x56	velocity fix (ENU)	0x37, auto
0x57	information about last computed fix	0x37
0x58	GPS system data/acknowledge	0x38
0x59	sat enable/disable & health heed	0x39
0x5A	raw measurement data	0x3A
0x5C	satellite tracking status	0x3C

Table A-14. Standard TSIP Report Packets

0x6D	all-in-view satellite selection	0x24, auto
0x6F	synchronized measurement output	0x6E
0x72	PV filter parameters	0x71
0x74	Altitude filter parameters	0x73
0x78	Max DGPS correction age	0x77
0x7B	NMEA message schedule	0x7A
0x82	differential position fix mode	0x62, auto
0x83	double-precision XYZ	auto, 0x37
0x84	double-precision LLA	auto, 0x37
0x85	differential correction status	0x65
0x8F-20	last fix with extra information (fixed point)	auto, 0x37, 0x8E-20
0x8F-17	UTM single precision	auto, 0x37
0x8F-18	UTM double precision	auto, 0x37
0x8F-26	SEEPROM write status	8E-26
0x8F-40	TAIP configuration	8E-40

A.15 Key Setup Parameters

A.15.1 Packet BB

Selecting the correct operating parameters has significant impact on receiver performance. Packet 0xBB (set receiver configuration) controls the key setup parameters.

The default operating parameters allow the receiver to perform well in almost any environment. The user can optimize the receiver to a particular application if the vehicle dynamics and expected level of obscuration are understood. If the receiver is then taken out of this environment, the specifically tuned receiver may not operate as well as a receiver with the default options.

The Table A-16 lists suggested parameter selections as a function of obscuration and whether accuracy or fix density is important. In this table, N/A indicates that the operating parameter is not applicable, DC (don't care) indicates that the user may choose the operating parameter.

Table A-15. Setup Parameters

Packet	Parameter	Accuracy	Fixes	Factory Default
0xBB	Fix mode	Man 3D	AUTO	AUTO
0xBB	Dynamics code	Land	Land	Land
0xBB	Elevation mask	10°	5°	5°
0xBB	Signal mask	6.0	4.0	2.0
0xBB	DOP mask	6.0	12.0	12.0
0xBB	DOP switch	N/A	8.0	5.0
0xBB	DGPS mode	manual on	manual off	auto
0xBB	DGPS correction age	10 Seconds	N/A	30 Seconds

The default values in Table A-17 allow the receiver to operate well under the most varied and demanding conditions. A user may choose to change the default parameters if the receiver is only required to perform in a specific or limited environment. The user should be warned that when the receiver is exposed to operating conditions which are different from the conditions described by the user setup, then the performance may be degraded.

Initially, the user must consider the environment in which the receiver is expected to operate. There is a trade-off between how frequently a position fix is output versus the absolute accuracy of the fix. The user must decide which takes priority and then make the appropriate selections. This becomes increasingly important when frequent satellite blockages are expected, as in downtown “urban canyon” environments and heavily foliated areas.

Following is a description of the key fields in Packet 0xBB.

Set Fix Mode

Packet 0xBB is used to choose the appropriate position fix mode for your application: 2-D, 3-D or AUTO. The default mode is AUTO 2-D/3-D, where the receiver first attempts to obtain a 3-D solution with a PDOP below both the DOP mask and DOP switch. If this is not possible, then the receiver attempts to obtain a 2-D solution with a DOP less than the DOP mask. This mode supplies fairly continuous position fixes even when there is frequent obscuration. This mode is preferable for most land or air applications, where altitude changes are occurring and there is occasional obscuration.

The highest accuracy fix mode is 3-D manual, where altitude is always calculated along with the latitude, longitude, and time. However, this requires four satellites with a PDOP below the DOP mask set in Packet BB in order to obtain a position. Normally, this will provide the most accurate solution. Thus, if only 3-D solutions are desired, then the user should request 3-D manual mode. Depending on how the PDOP mask is set, this may be restrictive when the receiver is subjected to frequent obscuration, or when the geometry is poor due to an incomplete constellation.

Alternatively, if the user only wants a 2-D solution, then 2-D manual should be requested. In this case, the receiver uses either the last altitude obtained in a 3-D fix, or the altitude supplied by the user. However, any error in the assumed altitude will affect the accuracy of the latitude and longitude solution.

High accuracy users should avoid the 2-D mode and should expect fixes with accuracies which are at best as accurate as the supplied altitude. If a marine user enters sea-level as the altitude, then small errors in the horizontal solution will occur when the sea state is rough or there are high tidal variations. However, these errors may be smaller than the altitude errors induced by SA, so 2-D may be preferable for a marine user who does not want to observe “unusual” altitudes.

Dynamics Code

The feature default is LAND mode, where the receiver assumes a moderate dynamic environment. In this case, the satellite search and re-acquisition routines are optimized for vehicle type environments. In SEA mode, the search and re-acquisition routines assume a low acceleration environment and reverts to user entered altitude in 2-D auto. In AIR mode, the search and re-acquisition routines are optimized for high acceleration conditions.

Elevation Mask

This is the minimum elevation angle for satellites to be used in a solution output by the receiver. Satellites which are near the horizon are typically more difficult to track due to signal attenuation, and are also generally less accurate due to higher variability in the ionospheric and tropospheric corruption of the signal. When there are no obstructions, the receiver can generally track a satellite down to near the horizon. However, when this mask is set too low, the receiver may experience frequent constellation switching due to low elevation satellites being obscured.

Frequent constellation switching is undesirable because position jumps may be experienced when SA is present and DGPS is not available to remove these effects. The benefit of a low elevation mask is that more satellites are available for use in a solution and a better PDOP may be yielded. The current mask is set to five degrees and provides a reasonable trade-off of the benefits and drawbacks. High accuracy users may prefer a mask angle around ten degrees, where the ionosphere and troposphere begin to be more predictable

Signal Level Mask

This mask defines the minimum signal strength for a satellite used in a solution. There is some internal hysteresis on this threshold which allows brief excursions below the threshold if lock is maintained and the signal was previously above the mask. The factory default mask has been set to 2.0. High accuracy users may use a slightly higher mask of 6.0-8.0, since weaker measurements may be slightly noisier and are often caused by reflected signals which provide erroneous ranges.

One should also resist the temptation to set the elevation and SNR masks too low. The satellite geometry is sometimes improved considerably by selecting low elevation satellites. They are, however, subject to significant signal degradation by the greater ionospheric and tropospheric attenuation that occurs. They are also subject to more obscuration by the passing scenery when the receiver is in a moving vehicle. The code phase data from those satellites is therefore more difficult to decode and therefore has more noise.



Note – A level of hysteresis in the signal level mask is allowed in the core operating software. The hysteresis allows the receiver to continue using satellite signals which fall slightly below the mask and prevents the receiver from incorporating a new signal until the signal level slightly exceeds the mask. This feature minimizes constellation changes caused by temporary fluctuations in signal levels.

DOP Mask and Switch

The DOP mask is the maximum DOP limit for any 2-D or 3-D position solution will be made. The DOP switch is the level at which the receiver stops attempting a 3-D solution, and tries for a 2-D solution when in automatic 2-D/3-D mode. The switch level has no effect in either manual mode. Raising the DOP mask will generally increase the fix density during obscuration, but the fixes with the higher DOP will be less accurate (especially with SA present). Lowering the mask will improve the average accuracy at the risk of lowering the fix density.

Set DGPS Mode

Packet 0xBB is used to set the differential GPS operating mode. The factory default mode is DGPS Auto. In this mode, the receiver computes differentially corrected positions whenever valid corrections are available. Otherwise, the receiver computes non-differentially corrected positions.

In manual DGPS mode, the receiver computes solutions only if corrections are available for the selected satellites. This is the most accurate mode but it is also the most selective, since the fix density is dependent on the availability of corrections. The applicability of corrections is determined by the maximum age which can be set using Packet 0xBB.

The AUTO mode avoids the fix density problem but opens the possibility of going in and out of DGPS mode, potentially resulting in position and velocity jumps. If accuracy is critical, use MANUAL DGPS mode. If fix density is critical, AUTO DGPS is the recommended mode.

In differential OFF mode, the receiver will not use corrections even if they are valid.

A.16 Packet Structure

TSIP packet structure is the same for both commands and reports. The packet format is:

```
<DLE> <id> <data string bytes> <DLE> <ETX>
```

Where:

- <DLE> is the byte 0x10
- <ETX> is the byte 0x03
- <id> is a packet identifier byte, which can have any value excepting <ETX> and <DLE>.

The bytes in the data string can have any value. To prevent confusion with the frame sequences <DLE> <id> and <DLE> <ETX>, every <DLE> byte in the data string is preceded by an extra <DLE> byte ('stuffing'). These extra <DLE> bytes must be added ('stuffed') before sending a packet and removed after receiving the packet. Notice that a simple <DLE> <ETX> sequence does not necessarily signify the end of the packet, as these can be bytes in the middle of a data string. The end of a packet is <ETX> preceded by an odd number of <DLE> bytes.

Multiple-byte numbers (integer, float, and double) follow the ANSI / IEEE Std. 754 IEEE Standard for binary Floating-Point Arithmetic. They are sent most-significant byte first. This may involve switching the order of the bytes as they are normally stored in Intel based machines. Specifically:

- UINT8 = Byte: An 8 bit unsigned integer.
- UINT16 = Word : A 16 bit unsigned integer.
- INT16 = Integer: A 16 bit integer.
- INT32 = Long: A 32 bit integer.
- UINT32 = ULong: A 32 bit unsigned integer.
- Single — Float, or 4 byte REAL has a precision of 24 significant bits, roughly 6.5 digits.
- Double — 8 byte REAL has a precision of 52 significant bits. It is a little better than 15 digits.

A.17 Packet Descriptions

A.17.1 Report Packet 0x13 - Packet Received

If a packet is received and it cannot be parsed, the packet is returned through the output port with a 0x13 inserted between the leading DLE and the input TSIP identification code. Two common causes of command failure are improper DLE stuffing and serial link noise.

A.17.2 Command Packet 0x1D - Clear Oscillator Offset

This packet commands the GPS receiver to set or clear the oscillator offset in battery backed memory. This is normally used for servicing the unit.

To clear the oscillator offset, one data byte is sent: The ASCII letter "C" = 0x43.

To set the oscillator offset, four data bytes are sent: The oscillator offset is expressed in Hertz as a single, real value.

A.17.3 Command Packet 0x1E - Clear Battery Backup, then Reset

This packet commands the GPS receiver to clear all battery back-up data and to perform a software reset. This packet contains one data byte, and will output packet 0x4B.

Table A-16. Command Packet 0x1E Format

Byte	Item	Type	Value	Definition
0	Reset mode	UINT8	0x4B	Cold start: Erase BBRAM and restart
			0x46	Factory reset: Erase BBRAM and SEEPROM and restart



Caution – All almanac, ephemeris, current position, mode, and communication port setup information is lost when executing the reset full factory configuration command. In normal use this packet should not be sent.



Caution – It is very helpful to keep a fresh copy of the current almanac, which is stored in the file GPSALM.DAT collected by the TSIPCHAT command "!". This allows near-instantaneous recuperation by the receiver in case of power loss or clearing of battery-backed memory by using the TSIPCHAT command "@" to load it back into the receiver memory.

A.17.4 Command Packet 0x1F - Request Software Versions

This packet requests information about the version of software running in the Navigation and Signal Processors. This packet contains no data. The GPS receiver returns Packet 0x45.

A.17.5 Command Packet 0x20 - Request Almanac

This packet requests almanac data for one satellite from the GPS receiver. This packet contains one data byte specifying the satellite PRN number. The GPS receiver returns packet 0x40.

A.17.6 Command Packet 0x21 - Request Current Time

This packet requests current GPS time. This packet contains no data. The GPS receiver returns Packet 0x41.

A.17.7 Command Packet 0x22 - Position Fix Mode Select

This packet commands the GPS receiver to operate in a specific position fix mode. This packet contains one data byte indicating the mode, as follows.

Table A-17. Command Packet 0x22 Position Fix Mode Select

Byte	Type	Value	Definition
0	UINT8	0	Auto (3-D / 2-D)
		3	Horizontal only (2-D)
		4	3-D only

In auto 3D/2D, the receiver tries for a 3D fix that meets the PDOP switch criteria set in the TSIP operating parameters packet. If the 3D DOP switch is exceeded, then the 2D HDOP is compared to the DOP mask. If this HDOP satisfies the DOP mask, then a 2-D fix is allowed. Otherwise, no fixing is allowed until tracking conditions change favorably.

Likewise, in Horizontal 2D only mode, the receiver is asked to perform 2D solutions only (using fixed or reference altitude) with a HDOP less than the DOP mask. If this criteria is not satisfied, then no fixing is allowed for the current tracking conditions.

In 3-D mode the receiver tries to obtain a 3D fix. However if the PDOP is greater than the DOP mask, fixing will not occur.

A.17.8 Command Packet 0x23 - Initial Position (XYZ Cartesian ECEF)

This packet provides the GPS receiver with an approximate initial position in XYZ coordinates. This packet is useful if the user has moved more than about 1,000 miles after the previous fix. (Note that the GPS receiver can initialize itself without any data from the user; this packet merely reduces the time required for initialization.) This packet is ignored if the receiver is already calculating positions. The data format is shown below.

To initialize with latitude-longitude-altitude, use Command Packet 0x2B.

Table A-18. Command Packet 0x23 Data Format

Byte	Item	Type	Units
0-3	X	Single	Meters
4-7	Y	Single	Meters
8-11	Z	Single	Meters

A.17.9 Command Packet 0x24 - Request GPS Receiver Position Fix Mode

This packet requests current position fix mode of the GPS receiver. This packet contains no data. The GPS receiver returns Packet 0x6D.

A.17.10 Command Packet 0x25 - Initiate Soft Reset & Self Test

This packet commands the GPS receiver to perform a software reset. This is equivalent to cycling the power. The GPS receiver performs a self-test as part of the reset operation. This packet contains no data. Following completion of the reset, the receiver will output the start-up messages (see Table A-5). The GPS receiver sends Packet 0x45 only on power-up and reset (or on request); thus if Packet 0x45 appears unrequested, then either the GPS receiver power was cycled or the GPS receiver was reset.

A.17.11 Command Packet 0x26 - Request Health

This packet requests health and status information from the GPS receiver. This packet contains no data. The GPS receiver returns packet 0x46 and 0x4B.

A.17.12 Command Packet 0x27 - Request Signal Levels

This packet requests signal levels for all satellites currently being tracked. This packet contains no data. The GPS receiver returns Packet 0x47.

A.17.13 Command Packet 0x28 - Request GPS Systems Message

This packet requests the most recent GPS system ASCII message sent with the navigation data by each satellite. This packet contains no data. The GPS receiver returns Packet 0x48 only if a GPS message has been received.

A.17.14 Command Packet 0x29 - Request Almanac Health Page

This packet requests the GPS receiver to send the health page from the almanac. This packet contains no data. The GPS receiver returns packet 49 hex.

A.17.15 Command Packet 0x2A - Altitude for 2-D Mode

Reference Altitude is the altitude used for manual 2-D positions if the altitude flag is set. Altitude is in units of HAE WGS-84 or MSL depending on the selected I/O options for the position. See section A.17.23. The Altitude Flag determines whether or not the Reference Altitude will be used. If set, it will be used. If cleared, altitude hold (last 3-D altitude) is used.



Note – With no data bytes, this packet requests the current values of these altitude parameters. In this case, the GPS receiver returns Packet 4A.

This packet sets or requests the altitude parameters used for the Manual 2-D mode: Reference Altitude and Altitude Flag. Packet 0x4A (type 2) is returned.

Table A-19 Packet 0x2A Set Reference Altitude Description

Byte	Item	Type	Definition
0-3	Altitude	Single	Reference altitude for 2-D

Table A-20. Packet 0x2A Clear Reference Altitude Only Description

Byte	Item	Type	Value	Definition
0	Altitude Flag	UINT8	0 x FF	Clear Altitude flag



Note – With no data bytes, this packet requests the current values of these altitude parameters. In this case, the GPS receiver returns Packet 4A.

A.17.16 Command Packet 0x2B - Initial Position (Latitude, Longitude, Altitude)

This packet provides the GPS receiver with an approximate initial position in latitude and longitude coordinates (WGS-84). This packet is useful if the user has moved more than about 1,000 miles after the previous fix. (Note that the GPS receiver can initialize itself without any data from the user; this packet merely reduces the time required for initialization.) This packet is ignored if the receiver is already calculating positions. The data format is shown in Table A-23:

Table A-21. Command Packet 0x2B Data Format

Byte	Item	Type	Units
0-3	Latitude	Single	Radians, north
4-7	Longitude	Single	Radians, east
8-11	Altitude	Single	Meters

Note – To initialize with ECEF position, use Command Packet 0x23.

A.17.17 Command Packet 0x2C - Set/Request Operating Parameters



Note – This Command Packet has been replaced by Command Packet 0xBB. Although the ACE II GPS retains compatibility with this command, it is recommended that you use the 0xBB Command Packet.

This packet sets the operating parameters of the GPS receiver or requests the current values. The data format is shown below. The GPS receiver returns packet 0x4C. See Section A.15 for a complete description of the key setup parameters.

The dynamics code indicates the expected vehicle dynamics and is used to set the search bandwidths.

The elevation angle mask determines the lowest angle at which the GPS receiver will attempt to track a satellite and use it in a position solution.

The signal level mask sets the required signal level for a satellite to be used for position fixes.

The DOP mask sets the maximum DOP with which position fixes are calculated. The DOP switch selects the PDOP at which a receiver in automatic 2-D/3-D mode will switch from 3-D to 2-D position solutions. If 4 or more satellites are available and the resulting PDOP is not greater than the DOP switch value, then 3-D fixes are calculated. Otherwise, 2-D fixes are calculated. The DOP switch is effective only in the automatic 2-D/3-D mode.

Table A-22. Command Packet 0x2C Data Format

Byte	Item	Type	Units	Default	Definition
0	Dynamics code	UINT8	---	1 - Land	(0) current value left unchanged (1) land/<120 knots (2) sea/<50 knots (3) air/<800 knots
1-4	Elevation angle mask	Single	radians	5°	
5-8	Signal level mask	Single	---	4	Minimum signal strength
9-12	PDOP mask	Single	---	12	Maximum PDOP setting
13-16	PDOP switch (3-D or 2-D)	Single	---	5	2D / 3D switch

A negative value in a “single” field leaves that current setting unchanged. This information is held in battery-backed memory.

To query current values, send the 0x2C command with the data field values of 0, for byte 1 and -1.0 for all other values

A.17.18 Command Packet 0x2D - Request Oscillator Offset

This packet requests the calculated offset of the GPS receiver master oscillator. This packet contains no data. The GPS receiver returns Packet 0x4D. This packet is used mainly for service. The permissible oscillator offset varies with the particular GPS receiver unit.

A.17.19 Command Packet 0x2E - Set GPS Time

This packet provides the approximate GPS time of week and the week number to the GPS receiver. The GPS receiver returns Packet 0x4E. The data format is shown below. The GPS week number reference is Week # 0 starting January 6, 1980. The seconds count begins at the midnight which begins each Sunday morning. This packet is usually not required when the battery back-up voltage is applied as the internal clock keeps time to sufficient accuracy. This packet is ignored if the receiver has already calculated the time from tracking a GPS satellite.



Note – See A.18.30, Report Packet 41 for information on the Extended GPS week number.

Table A-23. Command Packet 0x2E Data Formats

Byte	Item	Type	Units
0-3	GPS time of week	Single	Seconds
4-5	Extended GPS week number	INT16	Weeks

A.17.20 Command Packet 0x2F - Request UTC Parameters

This packet requests the current UTC-GPS time offset (leap seconds). The packet has no data. The receiver returns packet 0x4F.

A.17.21 Command Packet 0x31 - Accurate Initial Position (XYZ Cartesian ECEF)

This packet is identical in content to Packet 0x23. This packet provides an initial position to the GPS receiver in XYZ coordinates. However, the GPS receiver assumes the position provided in this packet to be accurate. This packet is used for satellite acquisition aiding in systems where another source of position is available. For acquisition aiding, the position provided by the user to the GPS receiver in this packet should be accurate to a few kilometers. For high-accuracy time transfer, position should be accurate to a few meters.

Table A-24 Command Packet 0x31 Data Format

Byte	Item	Type	Units
0-3	X-axis	Single	Meters
4-7	Y-axis	Single	Meters
8-11	Z-axis	Single	Meters

A.17.22 Command Packet 0x32 - Accurate Initial Position (Latitude, Longitude, Altitude)

This packet is identical in content to Packet 0x2B. This packet provides the GPS receiver with an accurate initial position in latitude, longitude, and altitude coordinates. However, the GPS receiver assumes the position provided in this packet to be accurate. This packet is used for satellite acquisition aiding in systems where another source of position is available. For acquisition aiding, the position provided by the user to the GPS receiver in this packet should be accurate to a few kilometers. For high-accuracy time transfer, position should be accurate to a few meters.

Table A-25 Command Packet 0x32 Data Format

Byte	Item	Type	Units
0-3	Latitude	Single	Radians, North
4-7	Longitude	Single	Radians, East
8-11	Altitude	Single	Meters

A.17.23 Command Packet 0x35 - Set/Request I/O Options

This packet requests the current I/O option states and optionally allows the I/O option states to be set as desired.

To request the option states without changing them, the user sends the packet with no data bytes included. To change any option states, the user includes 4 data bytes with the values. The I/O options, their default states, and the byte values for all possible states are shown below. These option states are held in battery-backed memory and can be set into non-volatile RAM (EEPROM) with the 0x8E-26 command. The GPS receiver returns Packet 0x55. See A.3 for information on saving the settings to non-volatile memory.

These abbreviations apply to the following table: ALT (Altitude), ECEF (Earth-centered, Earth-fixed), XYZ (Cartesian coordinates), LLA (latitude, longitude, altitude), HAE (height above ellipsoid), WGS-84 (Earth model (ellipsoid)), MSL geoid (mean sea level), and UTC (coordinated universal time).

Table A-26. Command Packets 0x35 and 0x55 Data Descriptions

Byte	Bit	Item	Type	Value	Definition	Associated Packet
Position						
0	0 (LSB)	XYZ ECEF	Bit	0	XYZ ECEF output off	0x42 or 0x83
				1	XYZ ECEF output on	
	1	LLA Output	Bit	0	LLA output off	0x4A or 0x84
				1	LLA output on	
	2	LLA ALT Output	Bit	0	HAE (WGS-84 datum)	0x4A / 0x84 0x8F-17 0x8F-18
				1	MSL geoid	
	3	ALT input	Bit	0	HAE (WGS-84 datum)	0x2A
1				MSL geoid.		
4	Precision-of-position output	Bit	0	Send single-precision packet.	0x42/0x4A/ 8F-17 0x83/84/ 8F-18	
			1	Send double-precision packet.		
5	Super Packet Output	Bit	0	Output no Super Packets.	0x8F-17, 0x8F-18 0x8F-20 Note 1. –	
			1	Output all enabled Super Packets.		
6-7	reserved					
Velocity						
1	0	XYZ ECEF	Bit	0	XYZ ECEF output off	0x43
				1	XYZ ECEF output on	
	1	ENU output	Bit	0	ENU output off	0x56
1				ENU output on		
2-7	reserved					
Timing						
2	0	Time Type	Bit	0	GPS time	0x42, 0x43, 0x4A, 0x83, 0x84, 0x56, 0x8F-17, 0x8F-18
				1	UTC	
1-7	reserved					

Table A-26. Command Packets 0x35 and 0x55 Data Descriptions (Continued)

Byte	Bit	Item	Type	Value	Definition	Associated Packet
Auxiliary / Pseudo Range Measurements						
3	0	Raw measuring	Bit	0 1	Raw measurements off Raw measurements on	0x5A
	1	Raw / Filtered	Bit	0 1	Raw PR's in 5A Filtered PR's in 5A	0x5A Note 2. –
	2	reserved				
	3	Output dB Hz instead of AMU	Bit	0 1	Output dB Hz Output AMU's	0x5A, 0x5C, 0x47, 0x6F
	4-7	reserved				



Note 1. – See the associated superpacket output, described in Section A.19. Packet 8E must be used to specify which superpacket is to be output.

Note 2. – Automatic output of 0x5A messages is supported in the ACE II GPS for backwards compatibility with older TSIP applications.

A.17.24 Command Packet 0x37 - Request Status and Values of Last Position and Velocity

This packet requests information regarding the last position fix and is only used when the receiver is not automatically outputting positions. The GPS receiver returns Report Packet 0x57 followed by the position/velocity packets specified in Command Packet 0x35.

A.17.25 Command Packet 0x38 - Request/Load Satellite System Data

This packet requests current satellite data (almanac, ephemeris, etc.) or permits loading initialization data from an external source (for example, by extracting initialization data from an operating GPS receiver unit via a data logger or computer and then using that data to initialize a second GPS receiver unit). The GPS receiver returns Packet 0x58. (Note that the GPS receiver can initialize itself without any data from the user; it merely requires more time.)

To request data without loading data, use only bytes 0 through 2; to load data, use all bytes. Before loading data, observe the caution notice below. The data formats are located in Report Packet 0x58.

Table A-27. Command Packet 0x38 Data Formats

Byte	Item	Type	Value	Definition
0	Operation	UINT8	1 2	Request data from ACE II GPS; Load data into ACE II GPS
1	Type of data	UINT8	2 3 4 5 6	Almanac Health page, T_oa, WN_oa Ionosphere UTC Ephemeris; request only
2	Sat PRN#	UINT8	0 1 - 32	Data that is not satellite - ID specific Satellite PRN number
3	Length (n)	UINT8		Number of bytes of data to be loaded
4 to n+3	Data	UINT8		Satellite data



Caution – Proper structure of satellite data is critical to ACE II GPS operation. Requesting data is not hazardous; Loading data improperly is hazardous. Use this packet only with extreme caution. The data should not be modified in any way. It should only be retrieved and stored for later download.



Note – Ephemeris cannot be loaded into the receiver.

A.17.26 Command Packet 0x39 - Set/Request Satellite Disable or Ignore Health

Normally the GPS receiver selects only healthy satellites (based on transmitted values in the ephemeris and almanac) which satisfy all mask values used in the position solution. This packet allows you to override the internal logic and force the receiver to either unconditionally disable a particular satellite, or to ignore a bad health flag. The GPS receiver returns Packet 0x59 for operation modes 3 and 6 only.

It should be noted that when viewing the satellite disables list, the satellites are not numbered but are in numerical order. The disabled satellites are signified by a “1” and enabled satellites are signified by a “0”.

Table A-28. Command Packet 0x39 Data Formats

Byte	Item	Type	Value	Definition
0	Operation	UINT8	1	Enable SV (default)
			2	Disable SV selection
			3	List enable - or - disable status of all 32 satellites
			4	Heed SV health on satellite(default)
			5	Ignore SV health on satellite
			6	List heed - or - ignore health on all 32 satellites
1	Satellite #	UINT8	0	All 32 satellites
			1 - 32	Any one satellite PRN number

This information is not held in battery-backed memory. At power-on and after a reset the default values are set for all satellites.



Caution – Improperly ignoring health can cause the GPS receiver software to lock up, as an unhealthy satellite may contain defective data. Use extreme caution in ignoring satellite health.

A.17.27 Command Packet 0x3A - Request Last Raw Measurement

This packet requests the most recent raw measurement data for one specified satellite. The GPS receiver returns packet 0x5A if data is available.

Table A-29. Command Packet 0x3A Data Format

Byte	Item	Type	Value	Definition
0	Satellite #	UINT8	0 1-32	All satellites in the current tracking set. Desired satellite.

A.17.28 Command Packet 0x3B - Request Current Status Of Satellite Ephemeris Data

This packet requests the current status of satellite ephemeris data. The GPS receiver returns packet 0x5B if data is available.

Table A-30. Command Packet 0x3B Data Format

Byte	Item	Type	Value	Definition
0	Satellite #	UINT8	0 1-32	All satellites Desired satellite.

A.17.29 Command Packet 0x3C - Request Current Satellite Tracking Status

This packet requests the current satellite tracking status. The GPS receiver returns Packet 0x5C if data is available.

Table A-31. Command Packet 0x3C Data Format

Byte	Item	Type	Value	Definition
0	Satellite #	UINT8	0 1 - 32	All satellites in the current tracking set Desired satellite

A.17.30 Command / Report Packet 0x3D - Primary Port Configuration



Note – This Command Packet has been replaced by Command Packet 0xBC. Although the ACE II GPS retains compatibility with this command, it is recommended that you use the 0xBC Command Packet.

This packet requests and optionally sets the primary port (port 1) configuration. This configuration includes the baud rate, number of bits, parity, and number of stop bits and also the language mode. When this packet is used only to request the configuration the packet contains no data bytes. When this packet is used to set the configuration, the packet contains the 5 data bytes shown below.

A 0x3D input packet, with or without data, is responded to with a 0x3D output packet. The language mode is defined as follows: For transmission, the language mode specifies whether TSIP packets or NMEA are output on primary port. For reception, the language mode specifies whether packets or RTCM data are received on the primary port. See Note 1.

The baud rate for the transmitter and the receiver can be set independently, but for TSIP, the number of bits, parity, and the stop bits are common between them. The default mode is packets for both transmission and reception at 9,600 baud with 8 data bits, odd parity, and one stop bit. For TAIP and NMEA, the default factory setting is 4800 baud, 8 data bits, no parity, 1 stop bit.

When the language mode for reception is set to RTCM (SC-104), raw RTCM (SC-104) data is accepted on the primary port for differential GPS corrections. These corrections are used only if the mode is set to Differential Auto or Manual DGPS (Differential On) with packet 0x62.



Note – RTCM input for the secondary port is the default mode at power-on to allow for direct connection to a radio modem. The default speed is 4800,8,none,1.

Table A-32. Command/Report Packet 0x3D Data Format

Byte	Bit	Item	Type	Value	Definition
0		Output Baud Rate	UINT8	4 5 6 8 9 11 28 12	300 baud 600 baud 1200 baud 2400 baud 4800 baud 9600 baud 19200 baud 38400 baud
1		Input Baud Rate	UINT8	As Above	As Above
2	0-1	Data bits code		2 3	7 data bits 8 data bits
2	2-4	Parity code		0 1 4	even parity odd parity no parity
3		Stop bits code	UINT8	7 15	1 stop bit 2 stop bits
4		Language mode for Transmission	UINT8	0 1 5	TSIP Off NMEA See Note 2.
5		Language mode for Reception	UINT8	0 1	TSIP RTCM SC-104 Note 3.

This information is held in battery-backed memory. After loss of battery-backed memory, the receiver will reset to the default values.



Note 1. – The default NMEA output is GGA and VTG at 1 second intervals.

Note 2. – Before the main port language for reception can be set to RTCM SC-104, the auxiliary port language for reception must be set to packets (using command 0xBC). Only one port may be set to receive RTCM at a time, not both.

A.17.31 Report Packet 0x40 - Almanac Data Page

Table A-33. Report Packet 0x40 Data Format

Byte	Item	Type	Units
0	satellite	UNIT8	(identification number)
1	T_zc	single	seconds
5	week number	INT16	weeks
7	eccentricity	single	(dimensionless)
11	T_oa	single	seconds
15	i_o	single	radians
19	OMEGA_dot	single	radians/second
23	square root A	single	(meters) ^{1/2}
27	OMEGA o	single	radians
31	omega	single	radians
35	M _o	single	radians

The symbols are defined in ICD-200.

T_zc is normally positive. If no almanac data is available for this satellite, then T_zc is negative. T_zc and the week number in this packet refer to the Z-count time and week number at the time the almanac was received. The remaining items are described in the ICD-GPS-200.

A.17.32 Report Packet 0x41 - GPS Time

This packet provides the current GPS time of week and the week number. The GPS receiver sends this packet in response to Packet 0x21 and during an update cycle. Update cycles occur approximately every 5 seconds. The data format is shown below.

Table A-34. Report Packet 0x41 Data Formats

Byte	Item	Type	Units
0-3	GPS time of week	Single	seconds
4-5	Extended GPS week number	INT16	weeks
6-9	GPS UTC offset	Single	seconds



Note – UTC time lags behind GPS time by an integer number of seconds; UTC = (GPS time) - (GPS UTC offset).



Caution – GPS week number runs from 0 to 1023 and then cycles back to week #0. Week #0 began January 6, 1980. There will be another week #0 beginning August 22, 1999. The extended GPS week number however, does not cycle back to 0. For example, August 22, 1999 starts week number 1024.

The seconds count begins with “0” each Sunday morning at midnight GPS time. A negative indicated time-of-week indicates that time is not yet known; in that case, the packet is sent only on request. The following table shows the relationship between the information in Packet 0x41, and the Packet 0x46 status code.

Table A-35. Packets 0x41 and 0x46 Status Code Relationships

Approximate Time Accuracy	Time Source	Sign (TOW)	Packet 46 Status Code
none	no time at all	-	0x01
unknown	approximate time from real-time clock or Packet 2E	+	0x01
20-50 msec + clock drift	time from satellite	+	0x02 - 0x0C
full accuracy	time from GPS solution	+	0x00



Note – Before using the GPS time from Packet 0x41, verify that the Packet 0x46 status code is 00 (“Doing position fixes”). This will ensure the most accurate GPS time.

A.17.33 Report Packet 0x42 - Single-Precision Position Fix, XYZ ECEF

This packet provides current GPS position fix in XYZ ECEF coordinates. If the I/O “position” option is set to “XYZ ECEF” and the I/O “Precision-of-Position output” is set to single-precision, then the GPS receiver sends this packet each time a fix is computed. The data format is shown below.

Table A-36. Report Packet 0x42 Data Formats

Byte	Item	Type	Units
0-3	X	Single	meters
4-7	Y	Single	meters
8-11	Z	Single	meters
12-15	Time-of-fix	Single	seconds

The time-of-fix is in GPS time or UTC as selected by the I/O “timing” option. Packet 83 provides a double-precision version of this information.

A.17.34 Report Packet 0x43 - Velocity Fix, XYZ ECEF

This packet provides current GPS velocity fix in XYZ ECEF coordinates. If the I/O “velocity” option is set to “XYZ ECEF”, then the GPS receiver sends this packet each time a fix is computed. The data format is shown below.

Table A-37. Report Packet 0x43 Data Formats

Byte	Item	Type	Units
0-3	X velocity	Single	meters/second
4-7	Y velocity	Single	meters/second
8-11	Z velocity	Single	meters/second
12-15	bias rate	Single	meters/second
16-19	time-of-fix	Single	seconds

The time-of-fix is in GPS time or UTC as selected by the I/O “timing” option.

A.17.35 Report Packet 0x45 - Software Version Information

This packet provides information about the version of software in the Navigation and Signal Processors. The GPS receiver sends this packet after power-on and in response to Packet 0x1F.

Table A-38. Report Packet 0x45 Data Formats

Byte	Item	Type
0	Major version number	UINT8
1	Minor version number	UINT8
2	Month	UINT8
3	Day	UINT8
4	Year number minus 1900	UINT8
5	Major revision number	UINT8
6	Minor revision number	UINT8
7	Month	UINT8
8	Day	UINT8
9	Year number minus 1900	UINT8

The first 5 bytes refer to the Navigation Processor and the second 5 bytes refer to the Signal Processor.

A.17.36 Report Packet 0x46 - Health of Receiver

This packet provides information about the satellite tracking status and the operational health of the Receiver. The receiver sends this packet after power-on or software-initiated resets, in response to Packet 0x26 and, during an update cycle. Packet 0x4B is always sent along with this packet.

Table A-39. Report Packet 0x46 Data Formats

Byte	Bit	Item	Type	Value	Definition
0		Status code	UINT8	0x00 0x01 0x02 0x03 0x08 0x09 0x0A 0x0B 0x0C	Doing position fixes Don't have GPS time yet Need initialization PDOP is too high No usable satellites Only 1 usable satellite Only 2 usable satellites Only 3 usable satellites The chosen satellite is unusable
1	0	Battery backup	Bit	0 1	OK BBRAM not available at start-up
1	4	Antenna feedline fault		0 1	OK short or open detected

The status codes in Byte 1 of Packet 0x46 are encoded into individual bits within the byte. The battery backup bit, once set, will remain set until the receiver is reset.

A.17.37 Report Packet 0x47 - Signal Levels for all Satellites

This packet provides received signal levels for all satellites currently being tracked or on which tracking is being attempted (i.e., above the elevation mask and healthy according to the almanac). The receiver sends this packet only in response to Packet 0x27. The data format is shown below.

Table A-40. Report Packet 0x47 Data Formats

Byte	Item	Type
0	Count	UINT8
1	Satellite number 1	UINT8
2- 5	Signal level 1	Single
6	Satellite number 2	UINT8
7-10	Signal level 2	Single
(etc.)	(etc.)	(etc.)

Up to 8 satellite number/signal level pairs may be sent, indicated by the count field. Signal level is normally positive. If it is zero then that satellite has not yet been acquired. If it is negative then that satellite is not currently in lock. The absolute value of signal level field is the last known signal level of that satellite.

Note – The signal level provided in this packet is a linear measurement of the signal strength after correlation or de-spreading. Units, either AMU or dBHz, are controlled by Packet 0x35.

A.17.38 Report Packet 0x48 - GPS System Message

This packet provides the most recent 22-byte ASCII message broadcast in the GPS satellite navigation message. The receiver sends this packet in response to Packet 0x28.

The message effectively is a bulletin board from the Air Force to GPS users. The format is free-form ASCII and is often encrypted. The message may be blank.

A.17.39 Report Packet 0x49 - Almanac Health Page

This packet provides health information on 32 satellites. Packet data consists of 32 bytes each containing the 6-bit health from Almanac page 25. The receiver sends this packet in response to packet 29 hex and when this data is received from a satellite. A value of 0 indicates the satellite is healthy. If all values are 0, this indicates that the health page is not yet available.

Table A-41. Report Packet 0x49 Almanac Health Page Data Formats

Byte	Item	Type
0	health of satellite #1	UINT8
1	health of satellite #2	UINT8
---	---	---
---	---	---
---	---	---
32	health of satellite #32	UNIT8

A.17.40 Report Packet 0x4A - 20 Byte Format

This packet provides current GPS position fix in LLA (latitude, longitude, and altitude) coordinates. If the I/O “position” option is set to “LLA” and the I/O “precision-of-position output” is set to single-precision, then the receiver sends this packet each time a fix is computed. Command Packet 35 controls position output (XYZ or LLA) and (single or Double) output precision. The data format is shown below:

Table A-42. Report Packet 0x4A Data Formats

Byte	Item	Type	Units
0-3	Latitude	Single	radians; + for north, - for south
4-7	Longitude	Single	radians; + for east, - for west
8-11	Altitude	Single	meters (HAE or MSL)
2-15	Clock Bias	Single	meters
6-19	Time-of-Fix	Single	seconds (GPS or UTC)

The LLA conversion is done according to the datum selected using Packet 0x8E-15. The default is WGS-84. Altitude is referred to the datum ellipsoid or the MSL Geoid, depending on which I/O “LLA altitude” option is selected. The time-of-fix is in GPS time or UTC, depending on which I/O “timing” option is selected.

This packet also is sent at start-up with a negative time-of-fix to report the current known position. Packet 0x84 provides a double-precision version of this information



Caution – When converting from radians to degrees, significant and readily visible errors will be introduced by use of an insufficiently precise approximation for the constant PI). The value of the constant PI as specified in ICD-GPS-200 is 3.1415926535898.

A.17.41 Report Packet 0x4A - 9 Byte Format

Report Packet 0x4A is also sent in response to the setting or requesting of the Reference Altitude Parameters using Command Packet 0x2A. These parameters can be used in the Manual 2-D mode.

Reference Altitude

The altitude used for manual 2-D positions if the altitude flag is set. Altitude is in units of HAE WGS-84 or MSL depending on the selected I/O options set for positioning with Command Packet 35.

Altitude Flag

A flag that determines whether or not the Reference Altitude will be used. If set, it will be used. If cleared, altitude hold (last 3-D altitude) will be used. The data format is shown in the following table.

Table A-43. Reference Altitude

Byte	Item	Type	Units
0-3	Reference Altitude	Single	Meters
4-7	Reserved	Single	
8	Altitude flag	UINT8	

A.17.42 Report Packet 0x4B - Machine/Code ID and Additional Status

The receiver transmits this packet in response to packets 0x25 and 0x26 and following a change in state. In conjunction with Packet 0x46, “health of receiver,” this packet identifies the receiver and may present status messages. The machine ID can be used by equipment communicating with the receiver to determine the type of receiver to which the equipment is connected. Then the interpretation and use of packets can be adjusted accordingly.

Table A-44. Report Packet 0x4B Data Formats

Byte	Item	Type/	Definition
0	Machine ID	UINT8	Receiver dependent
1	Status 1	UINT8	See Table A-46
2	Status 2	UINT8	Bit 0 = Super packets supported

The status codes are encoded into individual bits within the bytes. The bit positions and their meanings are shown in Table A-46.

Table A-45. Report Packet 0x4B Bit Positions and Descriptions

Status 1 Bit Positions	Meaning if bit value = 1
0 (LSB)	Not used
1	Real-time Clock is not available at power-up.
2	Not used
3	The almanac stored in the receiver is not complete and current.
4-7	Not used

A.17.43 Report Packet 0x4C - Report Operating Parameters



Note – This Command Packet has been replaced by Command Packet 0xBB. Although the ACE II GPS retains compatibility with this command, it is recommended that you use the 0xBB Command Packet.

This packet provides several operating parameter values of the receiver. The receiver sends this packet in response to packet 2C hex. The dynamics code indicates the expected vehicle dynamics and is used to assist the initial solution. The elevation angle mask determines the lowest angle at which the SVeeSix series receiver tries to track a satellite. The signal level mask sets the required signal level for a satellite to be used for position fixes.

The PDOP mask sets the maximum PDOP with which position fixes are calculated. The PDOP switch sets the threshold for automatic 3D/2D mode. If four or more satellites are available and the resulting PDOP is not greater than the PDOP mask value, then 3-dimensional fixes are calculated.

Table A-46. Report Packet 0x4C Data Formats

Byte	Item	Type	Default	Value
0	Dynamics code	UINT8	6-channel (1) land (2) sea (3) air	<120 knots <50 knots <800 knots
1-4	Elevation angle mask	single/ radians	5° = .08 radians	
5-8	Signal level mask	single	2.0	
9-12	DOP mask	single	12.0	
13-16	PDOP switch (3D or 2D)	single	5.0	

This information is held in battery-backed memory.

A.17.44 Report Packet 0x4D - Oscillator Offset

This packet provides the current value of the receiver master oscillator offset in Hertz at carrier. This packet contains one single number. The receiver sends this packet in response to Packet 0x2D. The permissible offset varies with the receiver unit.

A.17.45 Report Packet 0x4E - Response to Set GPS Time

Indicates whether the receiver accepted the time given in a Set GPS time packet. the receiver sends this packet in response to Packet 0x2E. This packet contains one byte.

Table A-47. Report Packet 0x4E Data Formats

Value	Meaning
ASCII "Y"	The receiver accepts the time entered via Packet 2E. The receiver has not yet received the time from a satellite.
ASCII "N"	The receiver does not accept the time entered via Packet 2E. The receiver has received the time from a satellite and uses that time. The receiver disregards the time in Packet 0x 2E.

A.17.46 Report Packet 0x4F - UTC parameters

This packet is sent in response to Command Packet 2F and contains 26 bytes. It reports the UTC information broadcast by the GPS system. For details on the meanings of the following parameters, consult ICD-200, Sections 20.3.3.5.2.4., 20.3.3.5.1.8, and Table 20-IX. On the simplest level, obtain the correct UTC offset from the 0x41 or 8F-20 message.

Table A-48. Report Packet 0x4F Data Formats

Byte	Item	Type
0-7	A0	double
8-11	A1	single
12-13	ΔT_{LS}	INT16
14-17	T_{OT}	single
18-19	WN_T	INT16
20-21	WN_{LSF}	INT16
22-23	DN	INT16
24-25	ΔT_{LSF}	INT16

A.17.47 Report Packet 0x55 - I/O Options

These abbreviations apply to the following table: ALT (Altitude), ECEF (Earth-centered, Earth-fixed), XYZ (Cartesian coordinates), LLA (latitude, longitude, altitude), HAE (height above ellipsoid), WGS-84 (Earth model (ellipsoid)), MSL geoid (Earth (mean sea level) mode), and UTC (coordinated universal time).

Table A-49. Command Packets 0x55 and 0x35 Data Descriptions

Byte	Bit	Item	Type	Value	Definition
Position					
0	0	XYZ ECEF	Bit	0 1	XYZ ECEF output off XYZ ECEF output on
0	1	LLA Output	Bit	0 1	LLA output off LLA output on
0	2	LLA ALT Output	Bit	0 1	HAE (WGS-84 datum) MSL geoid
0	3	ALT input	Bit	0 1	HAE (WGS-84 datum). MSL geoid.
0	4	Precision-of-position output	Bit	0 1	Send single-precision packet. Send double-precision packet.
0	5	Super Packet Output	Bit	0 1	Output no Super Packets. Output all enabled Super Packets.
0	6-7	reserved			
Velocity					
1	0	XYZ ECEF	Bit	0 1	XYZ ECEF output off XYZ ECEF output on
1	1	ENU output	Bit	0 1	ENU output off ENU output on
1	2-7	reserved			
Timing					
2	0	Time Type	Bit	0 1	GPS time UTC
2	1-7	reserved			
Auxiliary / Range Measurements					
3	0	Raw measuring	Bit	0 1	Raw measurements off Raw measurements on
3	1	Raw / Filtered	Bit	0 1	Raw PR's in 5A Filtered PR's in 5A
3	2	reserved			
3	3	Output dB Hz instead of AMU	Bit	0 1	Output dB Hz Output AMU's
3	4-7	reserved			



Note 1. – See the associated superpacket output, described later in this appendix. Packet 8E must be used to specify which superpacket is to be output.

Note 2. – Automatic output of 0x5A messages is supported in the ACE II GPS for backwards compatibility with older TSIP applications.

A.17.48 Report Packet 0x56 - Velocity Fix, East-North-Up (ENU)

If East-North-Up (ENU) coordinates have been selected for the I/O “velocity” option, the receiver sends this packet under the following conditions:

- Each time that a fix is computed
- In response to Packet 0x37 (last known fix)

The data format is shown below.

Table A-50. Report Packet 0x56 Data Formats

Byte	Item	Type	Units
0-3	East Velocity	Single	m/s; + for east, - for west
4-7	North Velocity	Single	m/s; + for north, - for south
8-11	Up Velocity	Single	m/s; + for up, - for down
12-15	Clock Bias Rate	Single	m/s
16-19	Time-of-Fix	Single	seconds (GPS or UTC)

The time-of-fix is in GPS or UTC time as selected by the I/O “timing” option.

A.17.49 Report Packet 0x57 - Information About Last Computed Fix

This packet provides information concerning the time and origin of the previous position fix. The receiver sends this packet, among others, in response to Packet 0x37. The data format is shown below.

Table A-51. Report Packet 0x57 Data Formats

Byte	Item	Type	Units	Byte 0 Value/Velocity
0	Source of information	UINT8	--	00 temporary no fix 01 good current fix
1	Mfg. diagnostic	UINT8	--	
2-5	Time of last fix	Single	seconds, GPS time	
6-7	Week of last fix	INT16	weeks, GPS time	

A.17.50 Report Packet 0x58 - Satellite System Data/Acknowledge from Receiver

This packet provides GPS data (almanac, ephemeris, etc.). The receiver sends this packet in response to Packet 0x38 (acknowledges the loading of data).

The data format is shown below.

Table A-52. Report Packet 0x58 Data Formats

Byte	Item	Type	Value	Definition
0	Operation	UINT8	1 2	Request data from receiver; Load data into receiver
1	Type of data	UINT8	2 3 4 5 6	Almanac Health page, T_oa, WN_oa Ionosphere UTC Ephemeris; request only
2	Sat PRN#	UINT8	0 1 - 32	Data that is not satellite - ID specific satellite PRN number
3	Length (n)	UINT8		Number of bytes of data to be loaded
4 to n+3	Data			



Note – If data is not available, byte 3 is set to 0 and “no” data is sent.

The binary almanac, health page, and UTC data streams are similar to Report Packets 0x40, 0x49, and 0x4F respectively, but these reports are preferred. To get ionosphere or ephemeris, this report must be used.

Table A-53. Report Packet 0x58 Almanac Data

Byte	Item	Type	Definition / ICD-GPS-200
4	t_oa_raw	UINT8	Sec 20.3.3.5.1.2
5	SV_HEALTH	UINT8	Sec 20.3.3.5.1.2
6-9	e	Single	Sec 20.3.3.5.1.2
10-13	t_oa	Single	Sec 20.3.3.5.1.2
14-17	i_o	Single	Sec 20.3.3.5.1.2
18-21	OMEGADOT	Single	Sec 20.3.3.5.1.2
22-25	sqrt_A	Single	Sec 20.3.3.5.1.2
26-29	OMEGA_0	Single	Sec 20.3.3.5.1.2
30-33	omega	Single	Sec 20.3.3.5.1.2
34-37	M_0	Single	Sec 20.3.3.5.1.2
38-41	a_f0	Single	Sec 20.3.3.5.1.2
42-45	a_f1	Single	Sec 20.3.3.5.1.2
46-49	Axis	Single	Sec 20.3.3.5.1.2
50-53	n	Single	Sec 20.3.3.5.1.2
54-57	OMEGA_n	Single	Sec 20.3.3.5.1.2
58-61	ODOT_n	Single	Sec 20.3.3.5.1.2
62-65	t_zc	Single	Sec 20.3.3.5.1.2. see Note 2.
66-67	weeknum	INT16	Sec 20.3.3.5.1.2
68-69	wn_oa	INT16	Sec 20.3.3.5.1.2



Note 1. – All angles are in radians.

Note 2. – If data is not available, t_zc is set to -1.0.

Table A-54. Report Packet 0x58 Almanac Health Data

Byte	Item	Type	Definition/ ICD-GPS-200
4	week # for health	UINT8	Sec 20.3.3.5.1.3
5-36	SV_health	UINT8	Sec 20.3.3.5.1.3
37	t_oa for health	UINT8	Sec 20.3.3.5.1.3
38	current t_oa	UINT8	units = seconds/2048
39-40	current week #	INT16	

Table A-55. Report Packet 0x58 Ionosphere Data

Byte	Item	Type	Definition / IDC-GPS-200
4-11	---	---	not used
12-15	alpha_0	Single	Sec 20.3.3.5.1.9
16-19	alpha_1	Single	Sec 20.3.3.5.1.9
20-23	alpha_2	Single	Sec 20.3.3.5.1.9
24-27	alpha_3	Single	Sec 20.3.3.5.1.9
28-31	beta_0	Single	Sec 20.3.3.5.1.9
32-35	beta_1	Single	Sec 20.3.3.5.1.9
36-39	beta_2	Single	Sec 20.3.3.5.1.9
40-43	beta_3	Single	Sec 20.3.3.5.1.9

Table A-56. Report Packet 0x58 UTC Data

Byte	Item	Type	Definition / IDC-GPS-200
4-16	---	---	not used
17-24	A_0	Double	Sec 20.3.3.5.1.8
25-28	A_1	Single	Sec 20.3.3.5.1.8
29-30	delta_t_LS	Integer	Sec 20.3.3.5.1.8
31-34	t_ot	Single	Sec 20.3.3.5.1.8
35-36	WN t	Integer	Sec 20.3.3.5.1.8
37-38	WN_LSF	Integer	Sec 20.3.3.5.1.8
39-40	DN	Integer	Sec 20.3.3.5.1.8
41-42	delta_t_LSF	Integer	Sec 20.3.3.5.1.8

Table A-57. Ephemeris

Byte	Item	Type	Definition / IDC -GPS-200
4	sv_number	UINT8	SV PRN number
5-8	t_ephem	Single	time of collection
9-10	weeknum	INT16	Sec 20.3.3.3, Table 20-I
11	codeL2	UINT8	Sec 20.3.3.3, Table 20-I
12	L2Pdata	UINT8	Sec 20.3.3.3, Table 20-I
13	SVacc_raw	UINT8	Sec 20.3.3.3, Table 20-I
14	SV_health	UINT8	Sec 20.3.3.3, Table 20-I
15-16	IODC	INT16	Sec 20.3.3.3, Table 20-I
17-20	T_GD	Single	Sec 20.3.3.3, Table 20-I
21-24	t_oc	Single	Sec 20.3.3.3, Table 20-I
25-28	a_f2	Single	Sec 20.3.3.3, Table 20-I
29-32	a_f1	Single	Sec 20.3.3.3, Table 20-I
33-36	a_f0	Single	Sec 20.3.3.3, Table 20-I

Table A-57. Ephemeris

Byte	Item	Type	Definition / IDC -GPS-200
37-40	SVacc	Single	Sec 20.3.3.3, Table 20-I
41	IODE	UINT8	Sec 20.3.3.4
42	fit_interval	UINT8	Sec 20.3.3.4
43-46	C_rs	Single	Sec 20.3.3.4
47-50	delta_n	Single	Sec 20.3.3.4
51-58	M_0	Double	Sec 20.3.3.4
59-62	C_uc	Single	Sec 20.3.3.4, radians
63-70	e	Double	Sec 20.3.3.4
71-74	C_us	Single	Sec 20.3.3.4, radians
75-82	sqrt_A	Double	Sec 20.3.3.4
83-86	t_oe	Single	Sec 20.3.3.4
87-90	C_ic	Single	Sec 20.3.3.4, radians
91-98	OMEGA_0	Double	Sec 20.3.3.4
99-102	C_is	Single	Sec 20.3.3.4, radians
103-110	i_0	Double	Sec 20.3.3.4
111-114	C_rc	Single	Sec 20.3.3.4
115-122	omega	Double	Sec 20.3.3.4
123-126	OMEGADOT	Single	Sec 20.3.3.4
127-130	IDOT	Single	Sec 20.3.3.4
131-138	Axis	Double	$= (\text{sqrt_A})^2$
139-146	n	Double	derived from delta_n
147-154	r1me2	Double	$= \text{sqrt}(1.0 - e^2)$
155-162	OMEGA_n	Double	derived from OMEGA_0, OMEGADOT
163-170	ODOT_n	Double	derived from OMEGADOT

Note – All angles are in radians.

A.17.51 Report Packet 0x59 - Status of Satellite Disable or Ignore Health

Normally the GPS receiver selects only healthy satellites (based on transmitted values in the ephemeris and almanac) which satisfy all mask values, for use in the position solution. This packet allows you to override the internal logic and force the receiver to either unconditionally disable a particular satellite or to ignore a bad health flag. The GPS receiver returns Packet 0x59 for operation modes 3 and 6 only. The data format is shown below.

Table A-58. Report Packet 0x59 Data Formats

Byte	Item	Type	Value	Definition
0	Operation	UINT8	3	The remaining bytes tell whether receiver is allowed to select each satellite.
			6	The remaining bytes tell whether the receiver heeds or ignores each satellite's health as a criterion for selection.
1 to 32	Status	32 Bytes (1 byte per satellite)	0	Enable satellite selection or heed satellite's health. Default value.
			1	Disable satellite selection or ignore satellite's health

This information is not held in battery-backed memory. At power-on and after a reset, the default values are reset for all satellites.

A.17.52 Report Packet 0x5A - Raw Measurement Data

This packet provides raw GPS measurement data. If the I/O “auxiliary” option has been selected, the receiver sends this data automatically as measurements are taken. The data format is shown below.

Note – A new Report Packet, 0x6F, has full pseudo-ranges and integrated Doppler.

Table A-59. Report Packet 0x5A Data Formats

Byte	Item	Type	Units
0	Satellite PRN Number	UINT8s	-----
1	reserved		
5	Signal Level	Single	AMU or dBHz
9	Code phase	Single	1/16th chip
13	Doppler	Single	Hertz
17	Time of Measurement	Double	sec

Application Note – Packet 0x5A provides the raw satellite signal measurement information used in computing a fix.

Satellite PRN (Byte 0) is a unique identification number of each of the 32 GPS satellites. The codephase (Byte 9) value is the average delay over the sample interval of the received C/A code and is measured with respect to the receiver's millisecond timing reference. Thus, it includes all receiver, satellite, and propagation biases and errors. It is expressed in 1/16th of a C/A code chip.

The Doppler (Byte 13) value is apparent carrier frequency offset averaged over the sample interval. It is measured with respect to the nominal GPS L1 frequency of 1575.42 MHz, referenced to the receiver's internal oscillator. Thus, it includes all receiver and satellite clock frequency errors. It is expressed in Hertz at the L1 carrier.

The time of measurement (Byte 17) is the center of the sample interval adjusted by adding the receiver supplied codephase (modulo mS) to a user determined integer number of mS between user and satellite.

The receiver codephase is expressed in 1/16th of a C/A code chip, this corresponds to:

$$\begin{aligned}
 1/16 \times \text{C/A code chip} &\approx 977.517\text{ns}/16 &\approx 61.0948 \text{ ns} \\
 &\approx 61.0948 \times \text{speed of light, m/s} \\
 &\approx 18.3158 \text{ meter}
 \end{aligned}$$

The integer millisecond portion of the pseudo-range must then be derived by utilizing the approximate user and satellite positions. Rough user position (within a few hundred kilometers) must be known; the satellite position can be found in its almanac / ephemeris data.

Each mS integer corresponds to:

$$\begin{aligned}
 \text{C/A code epoch} \times \text{speed of light} &= 1 \text{ ms} \times \text{speed of light, m/s} \\
 &\approx 300\text{km (approx.)} \\
 &\approx 299.792458 \text{ km (precise)}
 \end{aligned}$$

The satellite time-of-transmission for a measurement can be reconstructed using the code phase, the time of measurement, and the user-determined integer number of milliseconds.



Note – The receiver occasionally adjusts its clock to maintain time accuracy within 1 msec. At this time, all pseudorange values for all satellites are adjusted upward or downward by one millisecond. Report packet 0x6F shows this clearly. Report packet 0x5A, check packet 0x83 or 0x84 for clock bias.

A.17.53 Report Packet 0x5B - Satellite Ephemeris Status

This packet is sent in response to packet 3B and when a new ephemeris (based on IODE) is received. It contains information on the status of the ephemeris in the receiver for a given satellite. The structure of packet 5B is as follows:

Table A-60. **Report Packet 0x5B Data Formats**

Byte	Item	Type	Units
0	SV PRN Number	UNIT8	
1-4	Time of Collection	single	seconds
5	Health	UNIT8	
6	IODE	UINT8	
7-10	toe	single	seconds
11	Fit Interval Flag	UINT8	
12-15	SV Accuracy (URA)	single	meters

A.17.54 Report Packet 0x5C - Satellite Tracking Status

This packet provides tracking status data for a specified satellite. Some of the information is very implementation-dependent and is provided mainly for diagnostic purposes. The receiver sends this packet in response to Packet 0x3C. The data format is shown in Table A-61.

Table A-61. Report Packet 0x5C Data Formats

Byte	Bit	Item	Type	Value	Definition
0		Satellite PRN number	UINT8	number 1 - 32	
1	0-2	reserved	Bits	reserved	
1	3-5	Channel	Bits	0-7	
1	6-7	reserved	Bits	reserved	
2		Acquisition flag	UINT8	0 1 2	Never acquired Acquired Re-opened search
3		Ephemeris flag	UINT8	0 1	Flag not set Good ephemeris for this satellite (<4 hours old, good health)
4-7		Signal level	Single	Same as in Packet 0x47	
8-11		GPS time of last measurement	Single	<0 >0	No measurements have been taken. Center of the last measurement taken from this satellite.
12-15		Elevation	Singles	radians	Approximate elevation of this satellite above the horizon. Updated about every 15 sec.s. Used for searching and computing measurement correction factors.
16-19		Azimuth	Single	radians	Approximate azimuth from true north to this satellite. Updated typically about every 3 to 5 minutes. Used for computing measurement correction factors.
20-23		reserved	UINT8	0	

A.17.55 Command Packet 0x60 - Type 1 Differential GPS Corrections

This packet provides the ACE II GPS with differential corrections from RTCM SC-104 record types 1 and 9, in the TSIP format. There is no response to this packet. If bit 6 is set, the corrections are as in RTCM Type 9 records. The format for this packet is shown in Table A-62:

Table A-62. Report Packet 0x60 Data Formats

Byte	Bit	Item	Type	Range	Units
0 - 1		Modified z-count	UINT16	0-5999	.6 SEC
2		Station health	UINT8	--	
3	0 - 5	Number of SVs in packet	Bits	0-31	0 - 5
3	6	Type 9 flag	Bit	0 1	type 1 type 9
3	7	Version 2 flag	Bit	1	must be set

The next 5 bytes are repeated as a group for each satellite. The SV PRN and scale factor contains the SV PRN in the lower 5 bits, and the scale factor in the upper 3 bits. Range corrections are scaled by 0.02 meters times 2 raised to the scale factor power. Range-rate corrections are scaled by 0.002 meters per second times 2 raised to the scale factor power. The format is shown in Table A-63.

Table A-63. Report Packet 0x60 Data Formats for Health and Power

Byte	Bit	Item	Type	Value	Definition
4+ (N*5)	0-4	SV PRN		0-31	"0" Is SV 32
4+ (N*5)	5-7	Scale factor		0 4 7	Low Scale factor (.02m,.002 m/s) High Scale factor (.32m, .032 m/s) Correction not usable
5+ (N*5)		Range correction	UINT16		RTCM-104
7+ (N*5)		Range-rate correction	UINT8		RTCM-104
8+ (N*5)		IODE	UINT8		

A.17.56 Command Packet 0x61 - Set Differential GPS Corrections

This TSIP packet provides the delta differential corrections from RTCM-104 record type 2. There is no response to this packet. Scale factors are version 1 unless the version 2 flag is set. The format for this packet is shown in Table A-64.

Table A-64. Command Packet 0x61 Data Formats

Byte	Bit	Item	Type	Value	Definition
0 - 1		Modified Z-count	UINT16	0-5999	.6 SEC
2	0-6	Number of SVs		0-31	
2	7	Version 2 flag	Bit	1	must be set
The next 3 bytes are repeated as a group for each satellite:					
3+(N*2)	0-4	SV PRN		0-31	"0" Is SV 32
3+(N*2)	5-7	Scale factor		0 4 7	Low Scale factor (.02m, .002 m/s) High Scale factor (.32m, .032 m/s) Correction not usable
4+(N*2)		Range correction	UINT16		RTCM-104

The units and scale factors are as defined by Packet 0x60. Delta range correction rates are not entered.

A.17.57 Command Packet 0x62 - Request/Set Differential Position Fix Mode



Note – This Command Packet has been replaced by Command Packet 0xBB. Although the ACE II GPS retains compatibility with this command, it is recommended that you use the 0xBB Command Packet to set the differential fix mode.

This packet requests the differential position fix mode of the GPS receiver. A single data byte is sent.

To request Report Packet 0x82, the data byte is set to 0xFF.

A.17.58 Command Packet 0x65 - Request Differential Correction Status

This packet requests the status of differential corrections for a specific satellite or for all satellites for which data is available. This packet contains only one byte specifying the PRN number of the desired satellite or zero to request all available. The response is a Packet 0x85 for each satellite if data is available. If the receiver has no valid data for any satellite, no reply will be sent.

A.17.59 Report Packet 0x6D - All-In-View Satellite Selection

This packet provides a list of satellites used for position fixes by the GPS receiver. The packet also provides the PDOP, HDOP, and VDOP of that set and provides the current mode (automatic or manual, 3-D or 2-D). This packet has variable length equal to 16+nsvs where “nsvs” is the number of satellites used in the solution.

The GPS receiver sends this packet in response to Packet 0x24 when the receiver is doing an overdetermined fix. The data format is shown in Table A-65.

Table A-65. Report Packet 0x6D Data Formats

Byte	Bit	Item	Type	Value	Definition
0	0-2	Dimension	UINT8	3	2D
				4	3D
0	3			0	Auto
				1	Manual
0	4-7			-	nsvs
1-4		PDOP	Single		PDOP
5-8		HDOP	Single		HDOP
9-12		VDOP	Single		VDOP
13-16		TDOP	Single		TDOP
(16+nsvs)		SV PRN	UINT8		

A.17.60 Command Packet 0x6E - Set or Request Synchronized Measurement Parameters

Packet 6E sets or requests the Synchronized Measurement parameters. The synchronized measurement reports are sent by the GPS receiver in Packet 0x6F.

Enable / Disable Synchronized Measurements

Controls whether synchronized measurements will be output at the output interval.



Note – Synchronized measurement outputs will only be available after the GPS receiver has made a position fix once the receiver is turned on or reset by Command Packet 0x25. This ensures that information within the synchronized measurement packet will be valid.

Output Level

The period of the synchronized measurement outputs is synchronized to the GPS time of week. For example, outputs occur when the GPS time of week equals (INT*N), where INT is the selected output interval and N is an integer.

Two forms of this packet are shown in Table A-66 and Table A-67. The response for both forms of this packet is Packet 0x6E, Synchronized Measurement Parameters.

Table A-66. Set Synchronized Measurement Parameters

Byte #	Item	Type	Value	Definition
0	Subcode	UINT8	1	DSM format
1	Enable Output	UINT8	0 1	Disable outputs Enable output
2	Output interval	UINT8	1-255	Output interval in seconds, synchronized to the GPS time of week

Table A-67. Request Synchronized Measurement Parameters

Byte #	Item	Type	Value	Definition
0	Subcode	UINT8	1	Synchronized measurement parameters

A.17.61 Report Packet 0x6E — Synchronized Measurements

Report Packet 0x6E reports the setting of synchronized measurement parameters. The values are shown in Table A-68. See Command Packet 0x6E for more information.

Table A-68. Set Synchronized Measurement Parameters

Byte #	Item	Type	Value	Definition
0	Subcode	UINT8	1	DSM Unfiltered pseudorange
			3	DSM filtered pseudorange
1	Enable Output	UINT8	0 1	Disable outputs Enable output
2	Output Interval	UINT8	1-255	Output interval in seconds, synchronized to the GPS time of week

A.17.62 Report Packet 0x6F, Subcode 1

Table A-69. Synchronized Measurements Report

Byte #	Item	Type	Value	Definition
0	Subcode	UINT8	1	DSM format
<i>Begin Preamble</i>				
1	Preamble	UINT8	2	Begin preamble
2–3	Length	INT16		Number of bytes: preamble to postamble inclusive
4–11	Receive Time	Double	<i>msecs</i>	Time of GPS week
12–19	Clock Offset	Double	<i>msecs</i>	Receiver clock offset
20	# of SVs	UINT8		Number of satellites
<i>Begin Packet Data (bytes = number of SVs times 27 bytes per SV)</i>				
21,48,...	SV PRN	UINT8	1–32	Pseudorandom number of satellite
22, 49,...	FLAGS1	UINT8	Table 0-2	Flag values show synchronized measurement status of satellite
23, 50,...	FLAGS2	UINT8	0	Reserved (set to zero)
24, 51,...	Elevation Angle	UINT8	<i>degrees</i>	Satellite elevation angle
25–26, 52–53,...	Azimuth	INT16	<i>degrees</i>	Satellite azimuth
27, 54,...	SNR	UINT8	<i>AMUs/4</i>	Number of AMUs times four
28–35, 55–62,...	Pseudorange	Double	<i>meters</i>	Full L1 C/A Pseudorange, filtered
36–43, 63–70,...	Carrier Phase	Double	<i>cycles</i>	L1 band Continuous Phase (truncated to integer value)
44–47, 71–74,...	Doppler	Single	<i>hertz</i>	L1 band Doppler
<i>End of the packet data</i>				
21+27n 22+27n	Checksum	INT16	—	Sum of bytes before checksum starting with preamble
23+27n	Postamble	UINT8	3	



Note – The sign convention provides for a carrier-phase decrease when the pseudorange increases and the Doppler is negative.

Table A-70. FLAGS1 Bit Assignments

Bit	Item	Type	Value	Definition
0 (LSB)	Reserved (set to zero)	Bit		
1	L1 Carrier-phase Cycle Slip	Bit	0	No
			1	Yes
2	Reserved (set to zero)	Bit	0	Reserved
3	Reserved (set to zero)	Bit	0	Reserved
4	Valid L1 Carrier-phase: I	Bit	0	No
			1	Yes
5	Reserved (set to zero)	Bit	0	Reserved (set to zero)
6	Reserved (set to zero)	Bit	0	Reserved (set to zero)
7 (MSB)	New position calculated	Bit	0	No
			1	Yes

A.17.63 Command Packet 0x70 - Filter Control

Trimble OEM receivers have a number of filters. Command 0x70 provides control for these filters. It returns Report 0x70. There are three filters associated with 0x70:

- Position-Velocity (PV) Filter
- Static Filter
- Altitude Filter

The Position-Velocity (PV) Filter is the main filter and is used to “soften” the effect of constellation switches on position fixes. The filter has no effect on velocity output and there is no lag due to vehicle dynamics. There may be a small increase in accuracy however.

A feature of the PV filter is the “Static Filter” which engages when the receiver is moving very slowly. This feature improves accuracy in the urban environment. The static filter should be turned off for the following applications:

- Slow-moving environments such as walking or drifting with the current
- When rooftop testing of receivers for moving applications

The altitude filter is a simple averaging filter with a time constant of a few seconds. It should be left on in marine and land applications.

To query for the current settings, use Command Packet 0x70 with no databytes. To input new settings, Command Packet 0x70 is sent with four data bytes, as shown in Table A-71. Also see A.3 for information on saving the settings to non-volatile memory.

Table A-71. Command Packet 70 Data Formats

Byte	Item	Type	Value	Definition
0	Position Velocity Filter	UINT8	0	Off
			1	On
1	Static Filter	UINT8	0	Off
			1	On
2	Altitude Filter	UINT8	0	Off
			1	On
3	Reserved	UINT8	reserved	

A.17.64 Report Packet 0x70

This report is sent as a response to Command Packet 0x70 as either a query or a set. It contains four bytes, as shown in Table A-71.

A.17.65 Command Packet 0x71 - Set/Request/Disable Position Filter

Note – To simply turning filters on and off, use Command Packet 0x70.

This command sets position filter parameters, enables/disables the filter, and requests the position filter parameters. The receiver returns Report Packet 0x72. To request filter parameters, this command is sent with no data bytes.

This packet controls two filters: a dynamic filter used when the unit is in motion, and a static filter. To turn both filters off, set byte 0 to 0. The filters can also be turned off individually. To turn off the static filter only, set byte 25 to 255. To turn off the dynamic filter only, set the single value of byte 1 - 4 to 1.0. In both cases, leave byte 0 set to 1. To set the parameters or enable/disable the filter, the data string contains 26 bytes. The message format is shown below.

Table A-72. Command Packet 0x71 Data Formats

Byte	Type	Value
0	UINT8	0=disable 1=enable
1-4	Single	0.0625
5	UNIT8	1
6	UNIT8	1
7	UNIT8	0
8	UNIT8	6
9-12	Single	0.1
13-16	Single	100.0
17-20	Single	1.21
21-24	Single	1,000,000.0
25	UNIT8	2



Note – When the filter is being disabled, the parameters are reset as well. Consequently, when the filter is enabled, care should be taken to reset all parameters to their desired values. Documentation on the effect of the individual position filter parameters on position is currently not available.

A.17.66 Report Packet 0x72 - Position Filter Parameters

Byte	Type	Value
0-1	UINT8	0=disable 1=enable
2-5	Single	0.0625
6-7	INT16	1
8-9	INT16	1
10-11	INT16	0
12-13	INT16	6
14-17	Single	0.1
18-21	Single	100.0
22-25	Single	1.21
26-29	Single	1,000,000.0
30-31	INT16	2

A.17.67 Command Packet 0x73 - Set/Request/Disable Altitude Filter



Note – To simply turning filters on and off, use Command Packet 0x70.

This command sets or requests the averaging count of the altitude filter. The receiver returns Report Packet 0x74.

To request altitude filter parameters, the command is sent with no data bytes.

To set the altitude filter parameters or disable the filter, the data string format is listed below:

Table A-73. Command Packet 0x73 Report

Byte	Item	Type	Value	Definition
0 - 3	Altitude Filter Constant	Single	0	Resets value to default
			1	Disables filter
			>1	Sets value to input

The old altitude average is always discarded and the averaging process is re-started with this command.

The default value depends on the dynamics code set in packet 0x2C.

A.17.68 Report Packet 0x74 - Altitude Filter Parameters

This packet is in response to Command Packet 73 and provides the parameter used in the altitude filter. The data string has one single byte, equal to the number of fixes averaged in the altitude filter. If the values is -1, the altitude filter is currently disabled.

Table A-74. Report 0x74 Field Descriptions

Byte	Item	Type	Value	Definition
0 - 3	Altitude Filter Constant	Single	-1	Altitude filter off
			>1	Sets value to input

A.17.69 Command Packet 0x75

Not available in ACE II GPS.

A.17.70 Report Packet 0x76

Not available in the ACE II GPS.

A.17.71 Command Packet 0x77 - Set/Request Maximum Age of Differential Corrections



Note – This Command Packet has been replaced by Command Packet 0xBB. Although the ACE II GPS retains compatibility with this command, it is recommended that you use the 0xBB Command Packet.

This command sets the maximum age at which differential corrections will still be used by the receiver. The default is 30 seconds. For best accuracy, 20 seconds is preferred if it is supported by the differential link. The receiver returns packet 78.

A differential reference station will output corrections at a specified rate, normally between 1 per second and 1 per 30 seconds. The corrections contain a time tag so when they arrive at the receiver (via radio link or some other means) their age can be determined. This command allows the maximum usable age to be set. Older corrections tend to be less accurate therefore a trade-off will need to be made based on available bandwidth and correction age as well temporary signal blockages. For high accuracy implementations this number can be set as well as 2 times the reference station output frequency. This age limit applies to corrections received in RTCM format (all types), TSIP packets 0x60 and 0x61 as well as TAIP DC and DD messages. To request the current setting, the packet is sent with no data bytes. To set the maximum age, 2 data bytes are sent containing an integer.

Table A-75. Command Packet 0x77 Report

Byte	Item	Type	Value	Definition
0-1	Max Age of Differential Corrections	INT16	2-90	Maximum Age (seconds)

A.17.72 Report Packet 0x78 - Maximum Age of Differential Corrections

This packet contains a 2 byte integer representing the maximum age in seconds which the receiver will consider differential corrections to still be valid. The default is 60 seconds and can be changes with packet 0x77. See Table A-70.

A.17.73 Command Packet 0x7A

The NMEA message determines whether or not a given NMEA message will be output. If the bit for a message is set, the message will be sent every “interval” seconds. Use the values shown in Table A-76 to determine the NMEA interval and message mask. While fixes are being generated, the output order is: ZDA, GGA, GLL, VTG, GSA, GSV, RMC. Some firmware versions output GGA at 1 second intervals until fixes begin.

Table A-76 Command Packet 0x7A and Report Packet 0x7B Data Formats

Byte	Bit	Item	Type	Value	Definition
0		Subcode	UINT8	0	
1		Interval	UINT8	1-255	Fix interval in seconds
2		Reserved	UINT8	0	
3		Reserved	UINT8	0	
4	0	RMC	Bit	0 1	Off On
4	1-7	Reserved	Bit	0	
5	0	GGA	Bit	0 1	Off On
5	1	GLL	Bit	0 1	Off On
5	2	VTG	Bit	0 1	Off On
5	3	GSV	Bit	0 1	Off On
5	4	GSA	Bit	0 1	Off On
5	5	ZDA	Bit	0 1	Off On
5	6-7	Reserved	Bit	0	

A.17.74 Report Packet 0x7B

This packet provides the NMEA settings and interval. See Table A-76 for the data format.

A.17.75 Report Packet 0x82 - Differential Position Fix Mode

This packet provides the differential position fix mode of the receiver. This packet contains only one data byte to specify the mode. The packet is sent in response to Packet 0x62 and whenever a satellite selection is made and the mode is Auto GPS / DGPS (modes 2 and 3). The receiver switches automatically between modes 2 and 3 based on the availability of differential corrections for a constellation which meets all other masks. If such a constellation is not available, then the receiver stays in its current automatic mode (2 or 3), and does not do position solutions.

Valid modes are:

- Mode 0 Manual GPS (Differential off) — The receiver does position solutions without differential corrections, even if the differential corrections are available.
- Mode 1 Manual DGPS (Differential on) — The receiver only does position solutions if valid differential correction data are available.
- Mode 2 Auto DGPS (Differential currently off) — The receiver is not receiving differential correction data for all satellites in constellation which meets all other masks, and is doing non-differential position solutions.
- Mode 3 Auto DGPS (Differential currently on) — The receiver is receiving differential correction data for all satellites in a constellation which meets all other masks, and is doing differential position solutions.

A.17.76 Report Packet 0x83 - Double-Precision XYZ Position Fix and Bias Information

This packet provides current GPS position fix in XYZ ECEF coordinates. If the I/O “position” option is set to “XYZ ECEF” and the I/O double position option is selected, the receiver sends this packet each time a fix is computed. The data format is shown in Table A-77.

Table A-77. Report Packet 0x83 Data Formats

Byte	Item	Type	Units
0-7	X	Double	meters
8-15	Y	Double	meters
16-23	Z	Double	meters
24-31	clock bias	Double	meters
32-35	time-of-fix	Single	seconds

The time-of-fix is in GPS time or UTC, as selected by the I/O “timing” option.

Packet 42 provides a single-precision version of this information.

A.17.77 Report Packet 0x84 - Double-Precision LLA Position Fix and Bias Information

This packet provides current GPS position fix in LLA coordinates. If the I/O “position” option is set to “LLA” and the double position option is selected, the receiver sends this packet each time a fix is computed. The data format is shown in Table A-80.

Table A-78. Report Packet 0x84 Data Formats

Byte	Item	Type	Units
0-7	latitude	Double	radians; + for north, - for south
8-15	longitude	Double	radians; + for east, - for west
16-23	altitude	Double	meters
24-31	clock bias	Double	meters
32-35	time-of-fix	Single	seconds

The time-of-fix is in GPS time or UTC, as selected by the I/O “timing” option.



Caution – When converting from radians to degrees, significant and readily visible errors will be introduced by use of an insufficiently precise approximation for the constant π (PI). The value of the constant π as specified in ICD-GPS-200 is 3.1415926535898.

A.17.78 Report Packet 0x85 - Differential Corrections Status

This packet provides the status of differential corrections for a specific satellite. It is sent in response to Packet 0x65. The format of this packet is shown in Table A-79.

Table A-79. Report Packet 0x85 Data Formats

Byte	Item	Type	Units	Values
0	Satellite PRN number	UINT8		
1	reserved	UINT8		0xFF
2	reserved	UINT8		0xFF
3	Satellite health (UDRE)	UINT8		
4	IODE 1	UINT8		
5	IODE 2	UINT8		
6	Z-count as Time-of-Week	Single	seconds	
10	Range correction	Single	meters	
14	Range-rate correction	Single	m/sec	
18	Delta range correction	Single	meters	

A.17.79 Packets 0x8E and 0x8F - Superpacket

Refer to Section A.19 for information on Packets 0x8E and 0x8F.

A.17.80 Command Packet 0xBB - Navigation Configuration

In query mode, Packet 0xBB is sent with a single data byte and returns Report Packet 0xBB.



Note – This Command Packet replaces packets 0x2C, 0x62, 0x75, and 0x77.

Table A-80. Command Packet 0xBB Query Mode Data Format

Byte #	Item	Type	Value	Definition	Default
0	Subcode	UINT8	0x00	Query mode	

TSIP Packet 0xBB is used to set GPS Processing options. The table below lists the individual fields within the 0xBB Packet. See Section A.3 for information on saving the settings to non-volatile memory.

Table A-81. Command and Report Packet 0xBB Field Descriptions

Byte #	Item	Type	Value	Definition	Default
0	Subcode	UINT8	0x00	Query mode	0x03
1	Operating Dimension	UINT8	0* 3 4	Automatic (2D/3D) Horizontal (2D) Full Position (3D)	Automatic
2	DGPS Mode	UINT8	0 1 2 or 3	DGPS off DGPS only DGPS auto	DGPS auto
3	Dynamics Code	UINT8	1 2 3 4	Land Sea Air Stationary	Land
4	reserved				
5-8	Elevation Mask	Single	0.0 - 1.57	Lowest satellite elevation for fixes	0.0873 (5)
9-12	AMU Mask	Single	0-25	Minimum signal level for fixes	2.0
13-16	DOP Mask	Single	0.2-100	Maximum DOP for fixes	12.0
17-20	DOP Switch	Single	0.2-100	Selects 2D/3D mode	5.0

Table A-81. Command and Report Packet 0xBB Field Descriptions

Byte #	Item	Type	Value	Definition	Default
21	DGPS Age Limit	UINT8	2-90	Maximum time to use a DGPS correction (seconds)	30
22-39	reserved				

A.17.81 Command Packet 0xBC - Protocol Configuration

TSIP Packet 0xBC is used to query the port characteristics. In query mode, Packet 0xBC is sent with a single data byte and returns Report Packet 0xBC. (See A.3 for information on saving the settings to non-volatile memory.)



Note – This Command Packet replaces packets 0x3D and 0x8E-03.

TSIP Packet 0xBC is used to set the communication parameters on Port 1 and Port 2. The table below lists the individual fields within the Packet 0xBC and provides query field descriptions.

Table A-82. Command Packet 0xBC Port Characteristics

Byte	Bit	Item	Type	Value	Definition
0		Port to Set	UINT8	0 1 0xFF	Port 1 Port 2 Current port
1		Input Baud Rate	UINT8	2 3 4 5 6 7 8 9	300 baud 600 baud 1200 baud 2400 baud 4800 baud 9600 baud 19200 baud 38400 baud
2		Output Baud Rate	UINT8	As above	As above
3		# Data Bits	UINT8	2 3	7 bits 8 bits
4		Parity	UINT8	0 1 2	None Odd Even
5		# Stop Bits	UINT8	0 1	1 bit 2 bits
6		Flow Control	UINT8	0	0 = none
7	0	TAIP input	Bit	0/1	off/on
	1	TSIP input	Bit	0/1	off/on

Table A-82. **Command Packet 0xBC Port Characteristics (Continued)**

Byte	Bit	Item	Type	Value	Definition
	2	reserved	Bit	0/1	off/on
	3	RTCM input	Bit	0/1	off/on
	4-7	reserved	Bit	0/1	off/on
8	0	TAIP output	Bit	0/1	off/on
	1	TSIP output	Bit	0/1	off/on
	2	NMEA output	Bit	0/1	off/on
	3-7	reserved	UINT8	0	None
9		reserved	UINT8	0	None



Note 1. – To set port 1 configuration, use port 2; to set port 2 configuration, use port 1.

Note 2. – The BC command settings are retained in battery-backed RAM.



Caution – TSIP input or output must have 8 databits (byte 3).

Caution – At least one port must be either TSIP input or TAIP input at all times.

A.18 TSIP Superpackets

Several packets have been added to the core TSIP protocol to provide additional capability for OEM receivers. In OEM packets 0x8E and their 0x8F responses, the first data byte is a sub-code which indicates the superpacket type. For example, in Packet 0x8E-15, 15 is the sub-code that indicates the superpacket type. Therefore the ID code for OEM packets is 2 bytes long followed by the data.

A.18.1 Command Packet 0x8E-03 - Set / Request Auxiliary Configuration



Note – This Command Packet has been replaced by Command Packet 0xBC. Although the ACE II GPS retains compatibility with this command, it is recommended that you use the 0xBC Command Packet.

This packet requests and optionally sets the AUX Port configuration. This configuration includes the baud rate, number of bits, parity, and number of stop bits and also the language mode. When this packet is used only to request the configuration the packet contains no data bytes. When this packet is used to set the configuration, the packet contains the 6 data bytes shown below.

A 0x8E-03 input packet, with or without data, is responded to with a 0x8F-03 output packet. The language mode is defined as follows. For reception, the language mode specifies whether packets or RTCM data are received on the AUX Port.

The default mode is RTCM for reception at 4800 baud with 8 data bits, no parity, and 1 stop bit. For NMEA transmission, the default mode is 4800 baud, 8 data bits, no parity and 1 stop bit. RTCM corrections are used only if the mode is set to Differential Auto or Manual DGPS (Differential On) with packet 0x62.

Table A-83. Command Packet 0x8E-03 Data Formats

Byte	Bit	Item	Type	Value	Definition
0		Subcode	UINT8	0x03	
1		Output Baud Rate	UINT8	4 5 6 8 9 11 28 12	300 baud 600 baud 1200 baud 2400 baud 4800 baud 9600 baud 19200 baud 38400 baud
2		Input Baud Rate	UINT8	As Above	As Above
3	0-1	Data bits code		2 3	7 data bits 8 data bits
3	2-4	Parity code		0 1 4	even parity odd parity no parity
4		Stop bits code	UINT8	7 15	1 stop bit 2 stop bits
5		Language mode for Transmission	UINT8	0 1 5	TSIP Off NMEA See Note 2.
6		Language mode for Reception	UINT8	0 1	TSIP RTCM SC-104 Note 3.



Note 1. – The default NMEA output is GGA and VTG at 1 second intervals.

Note 2. – Before the main port language for reception can be set to RTCM SC-104, the auxiliary port language for reception must be set to TSIP (using command 0x8E-03). Only one port may be set to receive RTCM at a time, not both.

This information is held in battery-backed memory. After loss of battery-backed memory, the default values are set.

A.18.2 Report Packet 0x8F-03 - Request Auxiliary Port Configuration

See Table A-85 for a description of this packet.

A.18.3 Command Packet 0x8E-15 - Set/Request Datum

This packet allows the user to change the default datum from WGS-84 to one of 180 selected datums or a user-entered custom datum. The datum is a set of 5 parameters which describe an ellipsoid to convert the GPS receiver's internal coordinate system of XYZ ECEF into Latitude, Longitude and Altitude (LLA). This will affect all calculations of LLA in packets 0x4A and 0x84.

The user may wish to change the datum to match coordinates with some other system (usually a map). Most maps are marked with the datum used and in the US the most popular datum for maps is NAD-27. The user may also wish to use a datum which is more optimized for the local shape of the earth in that area. However, these optimized datum are truly "local" and will provide very different results when used outside of the area for which they were intended. WGS-84 is an excellent general ellipsoid valid around the world. See A.3 for information on saving the settings to non-volatile memory.

To request the current datum setting, one data byte is sent. Report Packet 0x8F-15 is returned.

Table A-84. Command Packet 0x8E-15 Field Descriptions

Byte	Type	Value
0	Superpacket ID	0 x 15

To change to one of the internally held datums, the packet must contain exactly 2 bytes representing the integer value of the index of the datum desired:

Table A-85. Command Packet 0x8E-15 Datum Index Field Descriptions

Byte	Type	Value
0	Superpacket ID	0 x 15
1-2	INT16	Datum index



Note 1. – To request the current datum, send Packet 8E-15 with no data bytes.

Note 2. – v7.80 does not support custom datums.



Note – Eccentricity Squared is related to flattening by the following equation:

$$e^2 = 2\rho - \rho^2$$

A.18.4 Report Packet 0x8F-15 - Current Datum Values

This packet contains 43 data bytes with the values for the datum currently in use and is sent in response to Packet 0x8E 15. Both the datum index and the 5 double precision values for that index will be returned.

Table A-86. Report Packet 0x8F-15 Data Formats

Byte	Type	Value
0	UINT8	Id for this sub-packet (always x15)
1-2	INT16	Datum Index
3-10	Double	DX
11-18	Double	DY
19-26	Double	DZ
27-34	Double	A-axis
35-42	Double	Eccentricity Squared



Note – A complete list of datums is provided at the end of this appendix. Eccentricity Squared is related to flattening by the following equation:

$$e^2 = 2\rho - \rho^2$$

A.18.5 Report Packet 0x8F-17 - UTM Single Precision Output

This packet reports position in UTM (Universal Transverse Mercator) format. The UTM coordinate system is typically used for U.S. and international topographical maps.

The UTM coordinate system lays out a world-wide grid consisting of the following:

- 60 North/South zones in 6° increments extending eastward from the International Date Line
- 10 East/West zones divided in 8° increments extending above and below the Equator.

Coordinates within these boundaries cover all surface locations from 80° South to 84° North and encircle the earth. Locations are indicated by offset from the equator and in the zones east of the International Date Line. These offsets are known as Northing and Easting and are expressed in meters. UTM is not usable in polar regions.

Table A-87. Report Packet 0x8F-17 Data Formats

Byte	Item	Type	Value
0	Subcode		0x17
1	Gridzone Designation	Char	
2-3	Gridzone	INT16	
4-7	Northing	Single	Meters
8-11	Easting	Single	Meters
12-15	Altitude	Single	Meters
16-19	Clock Bias	Single	Meters
20-23	Time of Fix	Single	Seconds

A.18.6 Report Packet 0x8F-18 - UTM Double Precision Output

This packet reports position in UTM (Universal Transverse Mercator) format. The UTM coordinate system is typically used for U.S. and international topographical maps.

The UTM coordinate system lays out a world-wide grid consisting of the following:

- 60 North/South zones in 6° increments extending eastward from the International Date Line
- 10 East/West zones divided in 8° increments extending above and below the Equator.

Coordinates within these boundaries cover all surface locations from 80° South to 84° North and encircle the earth. Locations are indicated by offset from the equator and in the zones east of the International Date Line. These offsets are known as Northing and Easting and are expressed in meters. UTM is not usable in polar regions.

Table A-88. Report Packet 0x8F-18 Field Descriptions

Byte	Description	Type	Value
0	Subcode		0x18
1	Gridzone Designation	Char	
2-3	Gridzone	INT16	
4-11	Northing	Double	Meters
12-19	Easting	Double	Meters
20-27	Altitude	Double	Meters
28-35	Clock Bias	Double	Meters
36-39	Time of Fix	Single	Seconds

A.18.7 Command Packet 0x8E-19 - Enable / Disable UTM Output

This packet allows the user to enable or disable the position report, in UTM format. The UTM (Universal Transverse Mercator) coordinate system is typically used for U.S. and international topographical maps. It is a world-wide grid consisting of 60: 6(N/S zones extending eastward from the international Date Line, and 10:8 (E/W bands above and below the equator). This covers the surface location from 80 south to 84 north. Locations are indicated by offset of the equator and in the zones east of the International Date Line. These offsets are known as northing and easting and are express in meters. UTM is not usable in polar regions.

This packet allows the user to enable or disable the position report in UTM (Universal Transverse Mercator) format. If bit 4, byte 0 of Command Packet 0x35 is set to double precision, the 0x8F-18 packets will be enabled. If the bit set to single precision, the 0x8F-17 packets will be enabled.

Table A-89. Command Packet 0x8E-19 Field Description

Byte	Description	Type	Value
0	Subcode		0/19
1	UTM Status	Char	'E' = Enable, 'D' = Disable

A.18.8 Report Packet 0x8F-19 UTM Status

This packet reports whether the 0x8F-17 and 0x8F-18 packets are enabled.

Table A-90. Command Packet 0x8F-19 Field Descriptions

Byte	Item	Type	Value
0	Subcode		0x19
1	UTM Status	Char	E = Enable D = Disable

A.18.9 Command Packet 0x8E-20 - Request last fix with Extra Information

This packet requests Packet 0x8F-20 or marks it for automatic output. If only the first byte (20) is sent, an 0x8F-20 report containing the last available fix will be sent immediately. If two bytes are sent, the packet is marked/unmarked for auto report according to the value of the second byte as shown in Table A-91. 0x37 can also be used for requesting 0x8F-20 if the 0x8F-20 is scheduled for auto output.

Table A-91. Command Packet 0x8E-20 Field Descriptions

Byte	Item	Type	Definition
0	Sub-packet id	UINT8	Id for this sub-packet (always 0x20)
1	Mark for Auto-report (See packet 35 byte 0 bit 5)	UINT8	0 = do not auto-report 1 = mark for auto-report



Note – Auto-report requires that superpacket output is enabled. Refer to Command Packet 35.

A.18.10 Report Packet 0x8F-20 - Last Fix with Extra Information (binary fixed point)

This packet provides complete information about the current position velocity fix in a compact, fixed-length 56-byte packet. The fields are fixed-point with precision matched to the receiver accuracy. It can be used for automatic position/velocity reports. The latest fix can also be requested by 0x8E-20 or 0x37 commands. The data format is shown in Table A-95:

Table A-92. Report Packet 0x8F-20 Data Formats

Byte	Bit	Item	Type	Value	Definition
0		Sub-packet id	UINT8		Id for this sub-packet (always 0x20)
1		KeyByte	UINT8		Reserved for Trimble DGPS Post-processing.
2-3		east velocity	INT16		0.005 m/s or 0.020 m/s See Note 1.
4-5		north velocity	INT16		0.005 m/s or 0.020 m/s See Note 1.
6-7		up velocity	INT16		0.005 m/s or 0.020 m/s See Note 1.
8-11		Time Of Week	UINT32		GPS Time in milliseconds
12-15		Latitude	INT32	-2^{30} to 2^{30}	WGS-84 latitude, 2^{-31} semicircle (-90° - 90°)
16-19		Longitude	UINT32	0 to 2^{32}	WGS-84 longitude, 2^{-31} semicircle (0° - 360°)
20-23		Altitude	UINT32		Altitude above WGS-84 ellipsoid, mm.
24	0	Velocity Scaling		0	0.005 m/s^2
				1	0.020 m/s^2
	1-7	reserved			
25	reserved				
26		Datum			Datum index + 1 0=unknown
27	0	Fix Available	Bit	0	Yes
				1	No
	1	DGPS Corrected	Bit	0	No
				1	Yes
	2	Fix Dimension	Bit	0	3D
				1	2D
3	Alt Hold	Bit	0	Last 3D Altitude	
			1	User-entered altitude	
4	Filtered	Bit	0	Unfiltered	
			1	Filtered	
	5-7	reserved			

Table A-92. Report Packet 0x8F-20 Data Formats (Continued)

Byte	Bit	Item	Type	Value	Definition
28		NumSVs	UINT8		Number of satellites used for fix. Will be zero if no fix was available.
29		UTC Offset	UINT8		Number of leap seconds between UTC time and GPS time.
30-31		Week	INT16		GPS time of fix, weeks.
32	0-5	PRN 1	UINT8	1-32	PRN of first satellite
	6-7	reserved			
33		IODE 1	UINT8		IODE of first satellite
34	0-5	PRN 2	UINT8	1-32	PRN of second satellite
	6-7	reserved			
35		IODE 2	UINT8		IODE of second satellite
36	0-5	PRN 3	UINT8	1-32	PRN of third satellite
	6-7	reserved			
37		IODE 3	UINT8		IODE of third satellite
38	0-5	PRN 4	UINT8	1-32	PRN of fourth satellite
	6-7	reserved			
39		IODE 4	UINT8		IODE of fourth satellite
40	0-5	PRN 5	UINT8	1-32	PRN of fifth satellite
	6-7	reserved			
41		IODE 5	UINT8		IODE of fifth satellite
42	0-5	PRN 6	UINT8	1-32	PRN of sixth satellite
	6-7	reserved			
43		IODE 6	UINT8		IODE of sixth satellite
44	0-5	PRN 7	UINT8	1-32	PRN of seventh satellite
	6-7	reserved			
45		IODE 7	UINT8		IODE of seventh satellite
46	0-5	PRN 8	UINT8	1-32	PRN of eighth satellite
	6-7	reserved			
47		IODE 8	UINT8		IODE of eighth satellite
48-55		Ionospheric Parameters			



Note 1. – Velocity scale controlled by byte 24, bit 1. Overflow = 0x8000.

Note 2. – See Section A-20, *Datums* for datum index tables.

A.18.11 Command Packet 0x8E-26 - SEEPROM Storage

The 0x8E-26 command is issued with no data to cause the current settings to be saved to non-volatile memory. See A.3 for information on saving the settings to non-volatile memory. The 0x8F-26 report is generated after the values have been saved.

Table A-93. Command Packet 0x8E-26 Definitions

Byte #	Item	Type	Value	Definition
0	Subcode	UINT8	0x26	Save Settings

A.18.12 Report Packet 0x8F-26 - SEEPROM Storage Status

This report will be issued after an 0x8E-26 command.

Table A-94. Report Packet 0x8F-26 Field Descriptions

Byte/	Item	Type	Value	Definition
0	Subcode	UINT8	0x26	Save Settings
1-4	reserved			

A.18.13 Command Packet 0x8E-40 - TAIP Configuration

The 0x8E-40 command can be issued with no data to request the current mask and internal settings. The 0x8F-40 report is sent in response to this command.

Table A-95. TAIP Configuration Request

Byte	Item	Type	Value	Definition
0	Subcode	UINT8	40	Request TAIP Configuration

The 0x8E-40 command can be issued with 5 data bytes to set the TAIP configuration.

Table A-96. TAIP Configuration Command Report Data Formats

Byte	Bit	Item	Type	Value	Definition	Default
0		Subcode	UINT8	0x40	Set TAIP config	0x40
1					TAIP sentence flags	0x0E
	0	ID Flag	Bit	0 1	off on	0=off
	1	CS Flag	Bit	0 1	off on	1=on
	2	EC Flag	Bit	0 1	off on	1=on
	3	FR Flag	Bit	0 1	off on	1=on
	4	CR Flag	Bit	0 1	off on	0=off
	5-7	reserved				
2		TAIP Auto Output Heartbeat Sentence	UINT8	0 2 6 8 11 14 15 16	AL CP ID LN PV ST TM VR	11 PV
3-4		Toh Offset	INT16	0-3599	Top of hour offset	0
5-6		HB rate	UINT16	0-3599	Auto output interval (sec)	5
7-10		Veh ID	String	"See TAIP ID"	Vehicle ID	"0000"

A.18.14 Report Packet 0x8F-40 - TAIP Configuration

The 8F:40 will be issued as a response to any valid 8E:40 command. See Table A-96 for report format and definitions.

A.19 Datums

Reference: DMA TR 8350.2 Second Edition, 1 Sept. 1991. DMA Technical Report, Department of Defense World Geodetic System 1984, Definition and Relationships with Local Geodetic Systems.

Continent:

Table 1: International Datums

Trimble Datum	Local Geodetic Datum	
Index	Name	Code
0	WGS-84	
6	WGS-72	
7	NAD-83	
8	NAD-02	
9	Mexican	
10	Hawaii	
11	Astronomic	
12	U.S. Navy	

Table 2: Africa

Trimble Datum	Local Geodetic Datum	
Index	Name	Code
15	Adindan Mean Solution (Ethiopia and Sudan)	ADI-M
16	Adindan Ethiopia	ADI-A
17	Adindan Mali	ADI-C
18	Adindan Senegal	ADI-D
19	Adindan Sudan	ADI-B
20	Afgooye Somalia	AFG
23	ARC 1950 Mean Solution	ARF-M
24	ARC 1950 Botswana	ARF-A
25	ARC 1950 Lesotho	ARF-B
26	ARC 1950 Malawi	ARF-C
27	ARC 1950 Swaziland	ARF-D
28	ARC 1950 Zaire	ARF-E
29	ARC 1950 Zambia	ARF-F
30	ARC 1950 Zimbabwe	ARF-G
31	ARC 1960 Mean Solution	ARS
32	ARC 1960 Kenya	ARS

Trimble Datum	Local Geodetic Datum	
33	ARC 1960 Tanzania	ARS
45	Cape South Africa	CAP
47	Carthage Tunisia	CGE
82	Liberia 1964 Liberia	LIB
87	Massawa Eritrea (Ethiopia)	MAS
88	Merchich Morocco	MER
90	Minna Nigeria	MIN-B
94	Schwarzeck Namibia	SCK
118	Old Egyptian 1907 Egypt	OEG

Table 3: Asia

Trimble Datum	Local Geodetic Datum	
1	Tokyo	
21	Ain El Abd 1970 Bahrain Island	AIN-A
51	Djakarta (Batavia) Sumatra (Indonesia)	BAT
71	Hong Kong 1963 Hong Kong	HKD
72	Indian 1975 Thailand	INH -A
73	Indian India and Nepal	IND-I
77	Kandawala Sri Lanka	KAN
79	Kertau 1948 West Malaysia and Singapore	KEA
91	Nahrwan Masirah Island (Oman)	NAH-A
92	Nahrwan United Arab Emirates	NAH-B
93	Nahrwan Saudi Arabia	NAH-C
124	Oman Oman	FAH
143	Qatar National Qatar	QAT
161	South Asia Singapore	SOA
164	Timbalai 1948 Brunei and East Malaysia (Sarawak and Sabah)	TIL
165	Tokyo Mean Solution (Japan, Okinawa and South Korea)	TOY-M
166	Tokyo South Korea	TOY-B
167	Tokyo Okinawa	TOY-C
176	Hu-Tzu-Shan Taiwan	HTN
179	Tokyo GIS Coordinates	TOY-B

Table 4: Australia

Trimble Datum	Local Geodetic Datum	
5	Australian Geodetic 1966 Australia and Tasmania	AUA
14	Australian Geodetic 1984 Australia and Tasmania	AUG
39	Australian Geodetic 1966 Australia and Tasmania	AUA

Table 5: Europe

Trimble Datum	Local Geodetic Datum	
4	European 1950 Mean Solution	EUR-M
13	European 1950 Mean Solution	EUR-M
54	European 1950 Mean Solution	EUR-M
55	European 1950 Cyprus	EUR-E
56	European 1950 Egypt	EUR-F
57	European 1950 England, Ireland, Scotland, Shetland Islands	EUR-G
58	European 1950 England, Ireland, Scotland, Shetland Islands	EUR-K
59	European 1950 Greece	EUR-B
60	European 1950 Iran	EUR-H
61	European 1950 Sardinia	EUR-I
62	European 1950 Sicily	EUR-J
63	European 1950 Norway and Finland	EUR-C
64	European 1950 Portugal and Spain	EUR-D
65	European 1979 Mean Solution	EUS
74	Ireland 1965 Ireland	IRL
125	Ordnance Survey of Great Britain Mean Solution	OGB-M
126	Ordnance Survey of Great Britain England	OGB-M
127	Ordnance Survey of Great Britain Isle of Man	OGB-M
128	Ordnance Survey of Great Britain Scotland and Shetland Islands	OGB-M
129	Ordnance Survey of Great Britain Wales	OGB-M
145	Rome 1940 Sardinia	MOD

Table 6: North America

Trimble Datum	Local Geodetic Datum	
0	WGS-84	
2	North American 1927 Mean Solution (CONUS)	NAS-C

Table 6: North America

Trimble Datum	Local Geodetic Datum	
3	Alaska Canada	
46	Cape Canaveral Mean Solution (Florida and Bahamas)	CAC
96	NAD 27 Western United States	NAS-B
97	NAD 27 Eastern United States	NAS-A
98	NAD 27 Alaska	NAS-D
99	NAD 27 Bahamas	NAS-Q
100	NAD 27 San Salvador	NAS-R
101	NAD 27 Canada	NAS-E
102	NAD 27 Alberta BC	NAS-F
103	NAD 27 East Canada	NAS-G
104	NAD 27 Manitoba Ontario	NAS-H
105	NAD 27 Northwest Territories Saskatchewan	NAS-I
106	NAD 27 Yukon	NAS-J
107	NAD 27 Canal Zone	NAS-O
108	NAD 27 Caribbean	NAS-P
109	NAD 27 Central America	NAS-N
110	NAD 27 Cuba	NAS-T
111	NAD 27 Greenland	NAS-U
112	NAD 27 Mexico	NAS-V
113	NAD 83 Alaska	NAR-A
114	NAD 83 Canada	NAR-B
115	NAD 83 CONUS	NAR-C
116	NAD 83 Mexico and Central America	NAR-D

Table 7: South America

Trimble Datum	Local Geodetic Datum	
42	Bogota Observatory Columbia	BOO
43	Compo Inchauspe 1969 Argentina	CAI
49	Chua Astro Paraguay	CHU
50	Corrego Alegre Brazil	COA
132	Provisional South Chilean 1963 Southern Chile (near 53°S)	HIT
133	Provisional South American 1956 Mean Solution (Bolivia, Chile, Columbia, Ecuador, Guyana, Peru, Venezuela)	PRP-M
134	Provisional South American 1956 Bolivia, Chile	PRP-A
135	Provisional South American 1956 Northern Chile (near 19°S)	PRP-B

Table 7: South America

Trimble Datum	Local Geodetic Datum	
136	Provisional South American 1956 Southern Chile (near 43°S)	PRP-C
137	Provisional South American 1956 Columbia	PRP-D
138	Provisional South American 1956 Ecuador	PRP-E
139	Provisional South American 1956 Guyana	PRP-F
140	Provisional South American 1956 Peru	PRP-G
141	Provisional South American 1956 Venezuela	PRP-H
149	South American 1969 Mean Solution (Argentina, Bolivia, Brazil, Chile, Columbia, Ecuador, Guyana, Paraguay, Peru, Trinidad Tobago, Venezuela)	SAN-M
150	South American 1969 Argentina	SAN-A
151	South American 1969 Bolivia	SAN-B
152	South American 1969 Brazil	SAN-C
153	South American 1969 Chile	SAN-D
154	South American 1969 Columbia,	SAN-E
155	South American 1969 Ecuador (Excluding Galapagos Islands)	SAN-F
156	South American 1969 Guyana	SAN-G
157	South American 1969 Paraguay	SAN-H
158	South American 1969 Peru	SAN-I
159	South American 1969 Trinidad and Tobago	SAN-K
160	South American 1969 Venezuela	SAN-L
171	Zanderij Surinam	ZAN

Table 8: Atlantic Ocean

Trimble Datum	Local Geodetic Datum	
34	Ascension Island 1958 Ascension Island	ASC
37	Astro Dos 71 /4 St. Helena Island	SHB
41	Bermuda 1957 Bermuda Islands	BER
70	Hjorsej 1955 Iceland	HJO
81	L.C.5 Astro 1961 Cayman Brac Island	LCF
86	Selvagem Grande 1938 Salvage Islands	SGM
95	Naparima, BWI Trinidad and Tobago	NAP
117	Observatorio Meteorologico 1939 Corvo and Flores Islands (Azores)	FLO
130	Pico De Las Nieves Canary Islands	PLN
142	Puerto Rico Puerto Rico and Virgin Islands	PUR
144	Qornoq South Greenland	QUO

Table 8: Atlantic Ocean

Trimble Datum	Local Geodetic Datum	
146	Santa Braz Sao Miguel, Santa Maria Islands (Azores)	SAO
148	Sapper Hill 1943 East Falkland Islands	SAP
162	Porto Santo 1936 Porto Santo and Madera Islands	POS
163	Graciosa Base Southwest 1948 Faial, Graciosa, Pico, San Jorg, and Terceira Islands (Azores)	GRA
168	Tristan Astro 1968 Tristan Da Cunha	TDC

Table 9: Indian Ocean

Trimble Datum	Local Geodetic Datum	
22	Anna 1 Astro 1965 Cocos Islands	ANO
66	Gan 1970 Republic of Maldives	GAA
75	ISTS 073 Astro 1969 Diego Garcia	IST
78	Kerguelen Island 1949 Kerguelen Island	KEG
80	Reunion Mascarene Island	REU
85	Mahe 1971 Mahe Island	MIK

Table 10: Pacific Ocean

Trimble Datum	Local Geodetic Datum	
35	Astro Beacon E 1945 Iwo Jima	ATF
36	Astro Tern Island (FRIG) 1961 Tern Island	TRN
38	Astronomical Station 1952 Marcus Island	TRN
40	Bellevue (IGN) Efate Erromango Island	IBE
44	Canton Astro 1966 Phoenix Island	CAO
48	Chatham Island Astro 1971 Chatham Island (New Zealand)	CHI
52	Dos 1968 Gizo Island (New Georgia Islands)	GIZ
53	Easter Island 1967 Easter Island	EAS
67	Geodetic Datum 1948 New Zealand	GEO
68	Guam 1963 Guam	GUA
69	Gux 1 Astro Guadalcanal Islands	DOB
76	Johnstone Island 1961 Johnstone Island	JOH
83	Luzon Philippines	LUZ-A
84	Luzon Mindanao Island	LUZ-B
89	Midway Astro 1961 Midway Islands	MID
119	Old Hawaiian Mean Solution	OHA-M

Table 10: Pacific Ocean

Trimble Datum	Local Geodetic Datum	
120	Old Hawaiian Hawaii	OHA-A
121	Old Hawaiian Kauai	OHA-B
122	Old Hawaiian Maui	OHA-C
123	Old Hawaiian Oahu	OHA-D
131	Pitcairn Astro 1967 Pitcairn Island	PIT
147	Santo (DOS) 1952 Espirito Santo Island	SAE
169	Viti Levu 1916 Viti Levu Island (Fiji Islands)	MVS
170	Wake Eniwetok 1960 Marshall Islands	ENW

Table 11: Non-Satellite Derived Datums

Trimble Datum	Local Geodetic Datum	
172	Bukit Rimpah Bangka and Belitung Islands (Indonesia)	BUR
173	Camp Area Astro Camp McMurdo Area, Antarctica	CAZ
174	Gunung Segara Kalimantan (Indonesia)	GSE
175	Herat North Afghanistan	HEN

B TSIP Toolkit User's Guide

The GPS Tool Kit program disk includes several TSIP interface programs designed to help developer's evaluate and integrate the GPS module and create GPS and differential GPS applications. These programs run on a PC-Windows 95 or NT platform. They are intended as a base upon which to build application specific software, so the source code in ANSI C is included for many of these programs. The GPS Tool Kit program disk includes the following programs:

32 bit Windows Applications

TSIPMonitor32: is a 32 bit windows application which interfaces with a TSIP-speaking receiver through a serial port. The program accepts TSIP reports and displays them in a window with fields for position, velocity, time, receiver status and satellite track status. It allows the user to exercise some basic TSIP commands. TSIPMonitor32 can also log TSIP report in binary format for later translation.

DOS Programs and C Source Code

TSIPCHAT.EXE: is a 16 bit DOS-based application which interfaces with a TSIP speaking receiver through a serial port. It allows the user to exercise all TSIP commands. TSIPCHAT can log a TSIP report in binary format. Source code is provided.

TSIPPRNT.EXE: is a 16 bit DOS-based application which interprets a binary TSIP data stream, such as logged by TSIPCHAT or TSIPMonitor32, and prints it to a file. Source code is provided.

For further information on the above programs, see the README file on the Toolkit disk.

B.1 TSIPMonitor32

TSIPMonitor32 requires Win95 or WinNT. Once the program is started, it immediately prompts for the serial port connected to the GPS receiver.

Figure B-1 TSIPMonitor32 - Serial Port Selection

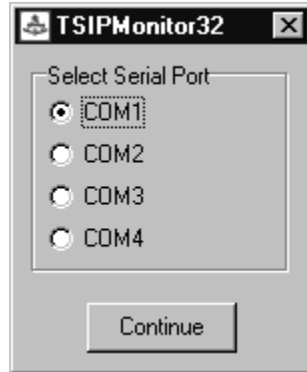

The main window is displayed once the GPS receiver is communicating with the application. Fields with question marks "?" indicate that information is not yet available.

Figure B-2 TSIPMonitor 32 - Main Window

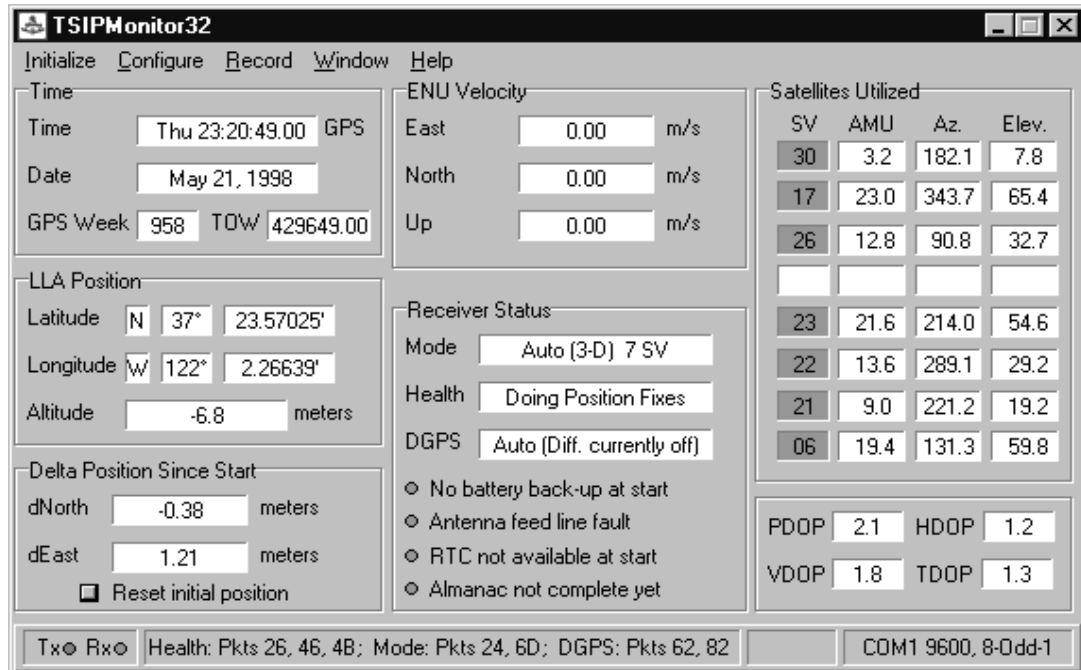

B.1.1 Delta Position

TSIPMonitor32 displays delta position which is the difference between the current position and the initial position. The initial position can be reset at anytime by selecting [Reset Initial Position], (see Figure B-2).

B.1.2 File Storage

TSIPMonitor32 provides for file storage of the raw binary TSIP stream directly from the serial port. To turn data collection on or off, use the record pull-down menu. The recorded binary data stream can be translated into an ASCII file with the program TSIPRNT.

C Trimble ASCII Interface Protocol (TAIP)

Trimble ASCII Interface Protocol (TAIP) is a Trimble-specified digital communication interface based on printable ASCII characters over a serial data link. TAIP was designed specifically for vehicle tracking applications but has become common in a number of other applications because of its ease of use. TAIP supports both scheduled and polled responses.

TAIP messages may be scheduled for output at a user specified rate starting on a given epoch from top of the hour. For communication robustness, the protocol optionally supports checksums on all messages. It also provides the user with the option of tagging all messages with the unit's user specified identification number (ID). This greatly enhances the functional capability of the unit in a network environment.

Additionally, given the printable ASCII format of all communication, TAIP is ideal for use with mobile data terminals, seven bit modems and portable computers. Although, sensors incorporating this protocol are shipped from the factory with a specific serial port setting, the port characteristics are fully programmable through TAIP messages.

This appendix is designed for easy reference to TAIP message formats and describes all the TAIP messages defined at the time of printing. Some of the defined TAIP messages are not supported by the ACE II GPS receiver. The ACE II GPS supports the following TAIP messages:

ACE II GPS supported TAIP messages include:

AL Altitude/Up Velocity	PR Protocol
AP Auxiliary Port Characteristics	PT Port Characteristic
CP Compact Position Solution	PV Position/Velocity Solution
DC Differential Corrections	RM Reporting Mode
DD Delta Differential Corrections	RT Reset Mode
ID Identification Number	ST Status
IP Initial Position	TM Time/Date
LN Long Navigation Message	VR Version Number

C.1 Message Format

All TAIP communication uses printable, uppercase ASCII characters. The interface provides the means to configure the unit to output various sentences in response to queries or on a scheduled basis. Each sentence has the following general format:

$$ABB\{C\}[\ ;ID=DDDD][\ ;*FF]<$$

where:

Table C-1. Message Formats

>	Start of new message
A	Message qualifier
BB	a two character message identifier
C	data string
DDDD	Optional 4 character vehicle ID
FF	Optional 2 character checksum
<	delimiting character
{x}	signifies that x can occur any number of times.
[x]	signifies that x may optionally occur once.

C.1.1 Start of a New Message

The > character (ASCII code 62 decimal) is used to specify the start of a new sentence.

C.1.2 Message Qualifier

A one character message qualifier is used to describe the action to be taken on the message. The following table lists the valid qualifiers.

Table C-2 Message Format Qualifiers

Qualifier	Action
Q	Query for a single sentence (sent to GPS sensor).
R	Response to a query or a scheduled report (from the sensor)
F	Schedule reporting frequency interval in seconds
S	Enables equipment to be initialized, and sets various message types.
D	Specify a minimum distance traveled and a minimum and maximum time interval for the next report

Details on the use of message qualifiers are given in section C.24, Communication Using TAIP.



Note – All TAIP message characters must be in uppercase.

C.1.3 Message Identifier

A unique two character message identifier consisting of alphabetical characters is used to identify type messages. For example: PR for Protocol or VR for Version Number.

C.1.4 Data String

The format and length of a data string is dictated by the message qualifier and the message identifier. The data string may contain any printable ASCII character with the exception of the >, <, and ; characters. Detailed descriptions of each message format are provided in the specific message sections of this Appendix. Most messages are length sensitive and unless otherwise specified, field separators, including spaces are not used.

C.1.5 Vehicle ID

A vehicle identification(ID) may optionally be used in all the communications with the sensor. Each sensor in the fleet may be assigned a four character alpha-numeric ID and be forced to output that ID in all messages. The default is: ID set to 0000 and the ID Flag set to F (false).

The sensor will check all incoming messages for ID. If no ID is specified, the sensor will accept the message. If the ID is included in messages but does not compare with the ID previously set, the message will be ignored. This applies even when the ID Flag is turned off.

C.1.6 Checksum

The checksum field provides for an optional two digit hex checksum value, which is computed as XOR of *all characters* from the beginning of the sentence up to and including the * character. If provided, the checksum is always the last element of the sentence before the message delimiter. The default mode of operation is to include checksum in sentences. The use of checksums can help in instances where the communication channel is noisy.

Example:

The following message to set the vehicle ID flag on includes checksum.

```
>SRM;ID_FLAG=T;*6F<
```

The checksum (6F) was generated by XOR'ing the ASCII codes for > and S then XOR'ing that result with the ASCII code for R and so forth, up to and including the * character.

C.1.7 Message Delimiter

The < character signifies end of a sentence and is used as the message delimiter.

C.2 Sample PV Message

The Position/Velocity Solution (PV) message is one of the more commonly used TAIP messages and most sensors using TAIP are set by default to output the PV message once every 5 seconds.

The following analysis of a typical PV message is provided to further explain the TAIP message protocol.

```
>RPV15714+3739438-1220384601512612;ID=1234;*7F<
```

Table C-3. Sample PV Message Fields

ID	Meaning
>	Start of Message Delimiter
R	Response Qualifier
PV	PV message Identifier
15714	GPS Time of Day
+3739438	Latitude
-12203846	Longitude
015	Speed
126	Heading
1	Source of Data
2	Age of Data
;ID=1234	Vehicle ID
*7F	Checksum
<	End of Message Delimiter



Note – Refer to the discussion of the PV message data string for more detail on how this message is interpreted.

C.3 Time and Distance Reporting

The 'D' message qualifier allows you to specify a minimum distance traveled as well as a minimum and maximum time interval for the next report. Units that are stationed at a fixed location can be programmed to report only when the unit moves "off station" or after a certain elapsed time since last report, but no more often than the specified minimum time interval.

The message format used with the 'D' qualifier is shown below:

```
>DAABBBBCCCCEEEEFFFF [ ; ID=GGGG ] [ ; *HH ] <
```

Table C-4. Time and Distance Reporting Message Format Qualifiers

ID	Meaning
>	start of message delimiter
D	the Distance message qualifier
AA	message to report (i.e. PV means Position Velocity message)
BBBB	minimum time (seconds) interval between reports (T_{interval})
CCCC	report epoch (number of seconds from top of the hour)
EEEE	delta distance (meters) from last reported distance
FFFF	maximum time (seconds) interval between reports (T_{max})
GGGG	optional vehicle identification number (user selected)
HH	optional checksum
<	End of message delimiter



Note – If BBBB = 0, then the message output is disabled. If FFFF = 0, maximum time feature is disabled (the unit will only report if current position is greater than or equal to the delta distance specified in EEEE).

Example:

When the message: >DPV0030000505000900;ID=0105< is sent to the GPS receiver, it specifies that vehicle number 105 ($GGGG = 0105$) is to report the Position Velocity message ($AA = PV$) whenever its current position differs from the previously reported position by at least 500 meters ($EEEE = 0500$), but no more often than every 30 seconds ($BBBB = 0030$) or less often than every 15 minutes ($FFFF = 0900$ seconds). The minimum and maximum time-out reports are to be issued with a 5 second offset ($CCCC = 0005$) from the top of the hour. The optional checksum was not used in this example. The square brackets, [...], shown in the format description above are used to indicate optional data. The brackets themselves are never included in the actual TAIP message string.

The 'D' message qualifier was designed by Trimble for use by Ambulance Companies to limit communication traffic between mobile units and the base when the ambulances are stationary on-station. When the ambulance has reached its stationary dispatch site, the operator signals the base by voice or by pushing a button on a Mobile Data Terminal (MDT) signifying that the unit is now on station. Once this communication is made, the base operator issues a 'D' qualifier and message so that the ambulance will only report either when it moves off-station or at specific reporting intervals.

C.4 Latitude and Longitude Conversion

The TAIP protocol reports latitude as positive north decimal degrees and longitude as positive east decimal degrees, using the WGS-84 datum. For your application, you may wish to convert to degrees, minutes and seconds. The following example illustrates the conversion of decimal degrees to degrees, minutes and seconds.

Example:

Given latitude and longitude in decimal degrees,

Latitude:	+37.39438 degrees
Longitude:	-122.03846 degrees

Convert latitude by multiplying the decimal fraction of degrees by 60 to convert to minutes

$$0.39438 \times 60 = 23.6628 \text{ minutes}$$

Retain the integer (23) portion as the minutes then multiply the decimal fraction by 60 to convert to seconds,

$$0.6628 \times 60 = 39.768 \text{ seconds}$$

Since the sign of the latitude in this example is positive the result is:

$$\text{Latitude: N } 37^{\circ} 23' 39.77''$$

The longitude is converted in the same fashion:

$$\text{Longitude: W } 122^{\circ} 02' 18.46''$$

Note – At the earth's equator, one degree of latitude and longitude represents 68.7 miles; therefore, 0.00001 degrees represents approximately 3.6 feet or 1.1 meters. Each second represents approximately 100.76 ft. (30.7 m).

C.5 Message Data Strings

The following table lists all the TAIP messages currently defined and comments regarding their application:

Table C-5. Message Data String Descriptions

Identifier	Message Name	Frequency and Distance	Query	Response/Report	Set
AL	Altitude/Vertical Velocity	X	X	X	X
AP	Auxiliary Port Characteristic		X	X	X
CP	Compact Position Solution	X	X	X	X
DC	Differential Corrections				X
DD	Delta Differential Corrections				X
ID	Vehicle ID	X	X	X	X
IP	Initial Position	X	X	X	X
LN	Long Navigation Message	X	X	X	
PR	Protocol		X	X	X
PT	Port Characteristic	X	X	X	X
PV	Position/Velocity Solution	X	X	X	X
RM	Reporting Mode	X	X	X	X
RT	Reset				X
ST	Status	X	X	X	
TM	Time/Date	X	X	X	
VR	Version Number	X	X	X	X

The data string format of each message is described in the following pages.



Note 1. – The Trimble GPS sensor may not support all the message types. Please refer to page 1 of this appendix for a list of the messages your sensor supports.

Note 2. – All TAIP message characters must be in uppercase.

C.6 AL Altitude/Up Velocity



Note – The first character of altitude or vertical velocity is “+” or “-”.

Data String Format:

AAAAABBBBBBCCCCDE

Table C-6. Altitude/Up Velocity Data String Descriptions

Item	# of Char	Units	Format	Value
GPS Time of day	5	Sec	AAAAA	
Altitude	6	Meter	BBBBBB	
Vertical Velocity	4	MPH	CCCC	
Source	1	n/a	D	0 = 2D GPS 1 = 3D GPS 2 = 2D DGPS 3 = 3D DGPS 6 = DR 8 = Degraded DR 9 = Unknown
Age of Data Indicator	1	n/a	E	2 = Fresh, <10 seconds 1 = Old, >10 seconds 0 = Not available
Total # of characters is 17				

Altitude is above mean sea level in WGS-84. The GPS time of day is the time of fix rounded to the nearest second. This message contains data obtained from the last 3 dimensional fix and may not be current.



Note – The data in this message is to be considered invalid and should not be used, if the Age of Data Indicator is equal to 0 (signifying data not available).

C.7 AM Alarm

ACE II GPS does not support this TAIP message.

C.8 AP Auxiliary Port Characteristics

Data String Format:

AAAA, B, C, D, E, F

Table C-7. Auxiliary Port Characteristics Data String Descriptions

Item	# of Char	Units	Format	(Value)
Baud Rate	4	n/a	AAAA	9600, 4800, 2400, 1200, or 0300
# of data bits	1	n/a	B	7 or 8
# of stop bits	1	n/a	C	1 or 2
Parity	1	n/a	D	N = None O = Odd E = Even
Auxiliary Port Number	1	n/a	E	1
Reserved	1	n/a	F	0
Total number of characters is 9 (includes commas)				

This message defines the characteristics for the auxiliary port. The auxiliary port must be the RTCM input port on differential ready sensors.

The default settings of the auxiliary port are 4800 baud, 8 data bits, parity none, and 1 stop bit.

Example:

The following command will set the auxiliary port characteristics to 2400 baud, 8 data bits, 1 stop bit and no parity.

```
>SAP2400,8,1,N,1,0<
```



Note 1. – See the inclusion of 0 in the reserved field.

Note 2. – The AP command applies only to receivers with dual serial ports.

Note 3. – The AP command requires commas between data fields.

C.9 CP Compact Position Solution



Note – The first character of latitude or longitude is “+” or “-”.

Data String Format:

AAAAABBBCCCDDDEEEFG

Table C-8. Compact Position Solution Data String Descriptions

Item	# of Char	Units	Format	(Value)
GPS Time of day	5	Sec	AAAAA	
Latitude	7	Deg	BBBCCCC	
Longitude	8	Deg	DDDEEEEE	
Source	1	n/a	F	0 = 2D GPS 1 = 3D GPS 2 = 2D DGPS 3 = 3D DGPS 6 = DR 8 = Degraded DR 9 = Unknown
Age of Data Indicator	1	n/a	G	2 = Fresh, <10 sec 1 = Old, >10 sec 0 = Not available
Total number of characters is 22				

Position is in latitude (positive north) and longitude (positive east) WGS-84. The GPS time of day is the time of fix rounded to the nearest second.



Note – The data in this message is to be considered invalid and should not be used, if the Age of Data Indicator is equal to 0 (signifying data not available).

C.10 DC Differential Corrections

The DC message provides the sensor with differential corrections from type-1 and type-9 RTCM-104 records. The numerical values are written out in hex format producing a two character hexadecimal number for each data byte.

Data String Format:

```
AAAABBCC{DDEEEFFGG}
```

Table C-9. DC Delta Differential Corrections Data String Descriptions

Item	# of Char	Type	Units	Format
Modified Z-count	4	Word	.6 sec	AAAA
Station health	2	Byte	N/A	BB
Number of SVs	2	Byte	N/A	CC
The next five bytes (10 characters) are repeated for each SV.				
SV PRN & scale factor	2	Byte	n/a	DD
Range correction	4	Word	RTCM-104	EEEE
Range-rate correction	2	Byte	RTCM-104	FF
IODE	2	Byte	n/a	GG

Units and scale factors are defined by RTCM-104, version 2. The SV PRN and scale factor contains the SV PRN in the lower 5 bits and the scale factor in the higher 3 bits. The scale factor has only three acceptable values:

- 0 - Use with low scale factor
- 4 - Use with high scale factor
- 7 - Do not use

Range corrections are scaled by 0.02 meters for low scale factor and 0.32 m/sec for high scale factor.



Note 1. – DC and DD TAIP messages are used to enclose differential corrections within the TAIP format.

Note 2. – DC and DD messages used to input corrections require only one communications channel. When the auxiliary port is used to input RTCM 104 corrections, it assumes a separate communications channel is available for broadcast and receipt of differential corrections.

Note 3. – The TAIP Software Toolkit does not support DC and DD messages.

C.11 DD Delta Differential Corrections

This message provides the sensor with delta differential corrections from RTCM-104 record type 2. The values are numerical values written out in hex format, thus for each byte of data there is a two digit hex number.

The format of the data string is as follows:

```
AAAABB{CCDDDD}
```

Table C-10. DD Delta Differential Corrections Data String Descriptions

Item	# of Char	Type	Units	Format
Modified Z-count	4	Word	.6 sec	AAAA
Number of SVs	2	Byte	n/a	BB
The next 3 bytes (6 characters) are repeated for each SV				
SV PRN	2	Byte	n/a	CC
Delta Range Correction	4	Word	RTCM-104	DDDD



Note 1. – The units and scale factors are as defined by RTCM-104 version 1. The health/UDRE/scale factor given for the specific SV in the most recent message DC is used. Delta range corrections are scaled by 0.02 meters times 2 raised to the health power.

The DC and DD TAIP messages described herein apply only to differential ready sensors and are provided to enclose differential corrections within the TAIP format.

Use of DC and DD messages to input corrections requires only one communications channel. Use of the auxiliary port to input RTCM-104 corrections assumes a separate communications channel is available for broadcast and receipt of differential corrections.

Note 2. – The TAIP software toolkit, GPSSK, does not support DC and DD messages.

C.12 ID Identification Number

Data String Format:

AAAA

Table C-11. Identification Number Data String Descriptions

Item	# of Char	Units	Format
Vehicle ID	4	n/a	AAAA
Total number of characters is 4			

This message is used to report or set the vehicle's (or sensor's) unique, four character, alpha-numeric, user assigned ID. The default at cold start is 0000.

Example:

The following message will set the vehicle ID to 101.

```
>SID0101<
```

The following is simply a response to a query for vehicle ID.

```
>RID0101<
```



Note – The sensor will always check incoming messages for ID and compare with the vehicle ID set in the sensor's memory. If no ID is included in the message, the sensor will assume a match and accept the message. If the message sent to the sensor does contain a vehicle ID but that ID does not match the ID previously set in the sensor, the message will be ignored. This process is followed even when the ID_Flag is turned off (refer to the message RM).

C.13 IP Initial Position

Data String Format:

AAABBBBCCCC

Table C-12. Initial Position Data String Descriptions

Item	# of Char	Units	Format
Initial Latitude	3	Deg	AAA
Initial Longitude	4	Deg	BBBB
Initial Altitude	5	10 Meters	CCCCC
Total number of characters is 12			

This is a very coarse initial position that the user can provide to aid the sensor in obtaining its first fix. This is particularly useful with sensors that do not have non-volatile (Battery Backed-up) memory. In such cases, every time the unit is powered up, it goes through a complete cold-start and it has absolutely no knowledge of where it is. Providing this message improves performance by decreasing the time to first fix and enhances the accuracy of the initial two dimensional navigation solutions by providing a reference altitude. In case of units with non-volatile memory, sending this message is only helpful if the unit has moved more than 1,000 miles since its previous fix. In either case, the sensor can initialize itself appropriately without any data from the user; it merely requires more time.



Note – For all the above values, the first character specifies the sign (+/-).

Example:

The following message will set the initial position to 37° North, 122° West, altitude 10 meters.

```
>SIP+37-122+0001<
```

C.14 LN Long Navigation Message



Note – The first character of latitude, longitude, altitude or vertical speed is “+” or “-”.

Data String Format:

AAAAA.BBBCCDDDDDDDEEEFFFHHIIJKKKLMMNOOP
PQQPPQQ...PPQRRRRRRRRRST

Table C-13. Long Navigation Message Data String Descriptions

Item	# of Char	Units	Format	Value
GPS Time of day	8	Sec	AAAAA.BBB	
Latitude	10	Deg	CCC.DDDDDDD	
Longitude	11	Deg	EEEE.FFFFFFFF	
Altitude above MSL	9	Ft	GGGGGGG.HH	
Horizontal Speed	4	MPH	III.J	
Vertical Speed	5	MPH	KKKK.L	
Heading	4	Deg	MMM.N	
Number of SVs used	2	n/a	OO	
SV Id (see note)	2	n/a	PP	
IODE (see note)	2	n/a	QQ	
Reserved	10	n/a	RRRRRRRRRR	
Source	1	n/a	S	0 = 2D GPS 1 = 3D GPS 2 = 2D DGPS 3 = 3D DGPS 6 = DR 8 = Degraded DR 9 = Unknown
Age of Data Indicator	1	n/a	T	2 = Fresh, <10 sec 1 = Old, >10 sec 0 = Not available
Total number of characters is 65+4x(number of SV's used)				



Note 1. – At least 2 satellites are required to get the LN Message.

Position is in Degrees, minutes, decimal minutes. And latitude is (positive north) and longitude (positive east) WGS-84. Heading is in degrees from True North increasing eastwardly. The GPS time of day is the time of fix rounded to the nearest second.

Note 2. – The data in this message is to be considered invalid and should not be used, if the Age of Data Indicator is equal to 0 (signifying data not available).

C.15 PR Protocol

The protocol message (PR) is the method used to control which I/O protocols are active on each of the two ACE II GPS ports. Each protocol can be set to:

- Off
- Input Only
- Output Only
- Both Input and Output

The PR data string format is:

[;TAIP=xy] [;TSIP=xy] [;NMEA=xy] [;RTCM=xy]

Table C-14. PR Data String Descriptions

Item	# of Char	Units	Format	(Value)
Port 1 Protocol	1	n/a	x	T = Both in and out I = Input only O= Output only F = Off N = Not available
Port 2 Protocol	1	n/a	y	T = Both in and out I = Input only O= Output only F = Off N = Not available

Sending the following message will set the receiver to TAIP in and out on PORT 1, and RTCM in, NMEA out on PORT 2.

>SPR;TAIP=TF;TSIP=FF;NMEA=FO;RTCM=FI<



Note 1. – There are two restrictions to setting protocols: RTCM is input only, and TAIP cannot be running on both ports at the same time.

Note 2. – If a protocol is not implemented within the application, x and/or y will have the value N, and any set message for that protocol is ignored.

It is possible to turn off all input processing on a port. If this is done, neither TAIP nor TSIP can be used to change the active protocols. The break sequence must used.

If you do not use battery back-up, all port characteristics will reset to the default after power is removed.

C.16 PT Port Characteristic

This message defines the characteristics for the primary TAIP port.

Data String Format:

AAAA, B, C, D

Table C-15. Port Characteristic Data String Descriptions

Item	# of Char	Units	Format	(Value)
Baud Rate	4	n/a	AAAA	9600, 4800, 2400, 1200, or 0300
# of data bits	1	n/a	B	(7 or 8)
# of stop bits	1	n/a	C	(1 or 2)
Parity	1	n/a	D	("N" = None) ("O" = Odd) ("E" = Even)
Total number of characters is 10 (includes commas)				

Most TAIP using sensors use the following default port characteristics

- 4800 baud
- 8 data bits
- 1 stop bit
- No parity



Note 1. – The characteristics set by this message will be stored in the sensor's battery backed ram. The ACE II GPS family of sensors do not include an internal battery but provide a battery back-up input line that may be used to retain memory when main power is removed.

Note 2. – If you do not use battery back-up, all port characteristics will reset to the default after power is removed.

Note 3. – The PT command uses commas between data fields.

C.17 PV Position/Velocity Solution



Note – The first character of latitude or longitude is “+” or “-”.

Data String Format:

AAAAABBBCCCDDDEEEFFFGGGHI

Table C-16. Position/Velocity Solution Data String Descriptions

Item	# of Char	Units	Format	Value
GPS Time of day	5	Sec	AAAAA	
Latitude	8	Deg	BBB.CCCCC	
Longitude	9	Deg	DDDD.EEEEE	
Speed	3	MPH	FFF	
Heading	3	Deg	GGG	
Source	1	n/a	H	0 = 2D GPS 1 = 3D GPS 2 = 2D DGPS 3 = 3D DGPS 6 = DR 8 = Degraded DR 9 = Unknown
Age of Data Indicator	1	n/a	I	2 = Fresh, <10 sec 1 = Old, >10 sec 0 = Not available
Total	30			

Position is in latitude (positive north) and longitude (positive east) WGS-84. Heading is in degrees from True North increasing eastwardly. The GPS time of day is the time of fix rounded to the nearest second.



Note – The data in this message is to be considered invalid and should not be used, if the Age of Data Indicator is equal to 0 (signifying data not available).

C.18 RM Reporting Mode

Data String Format:

```
[ ;ID_FLAG=A ] [ ;CS_FLAG=B ] [ ;EC_FLAG=C ] [ ;FR_FLAG=D ]
[ ;CR_FLAG=E ]
```

Table C-17. Reporting Mode Data String Descriptions

Item	# of Char	Units	Format	Value
ID Flag	1	n/a	A	T = True F = False
CS Flag	1	n/a	B	T = True F = False
EC Flag	1	n/a	C	T = True F = False
FR Flag	1	n/a	D	T = True F = False
CR Flag	1	n/a	E	T = True F = False

ID Flag determines whether the unit is to include the vehicles ID with each report.

CS Flag determines whether the unit is to include a checksum as part of each message.

EC Flag, when set, will cause the unit to echo back all complete and properly formatted set commands, except for DC and DD, with a “Response qualifier”. This provides an easy way to verify that the unit did in fact receive the intended data.

FR Flag indicates whether the unit is to report messages automatically per their individually scheduled frequency. When set to false, the unit will only respond when queried for a specific message.

CR Flag, when set to True, will cause the sensor to append a carriage return and line feed [CR] [LF] to the end of each message output. This is useful when viewing the unencoded sensor responses on a terminal or a PC.

The default value at start-up for ID flag and the CR flag is false; the default for CS, EC and FR flags is true.

Example:

The following command will turn checksums off and carriage return on:

```
>SRM;CS_FLAG=F;CR_FLAG=T<
```



Note – Note the use of semicolon before the flag name.

C.19 RT Reset Mode

Data String Format:

Any one of the following data strings can be set. Upper case characters are required.

[]
[COLD]
[FACTORY]
[SAVE_CONFIG]

Table C-18. Reset Mode Data String Descriptions

Message	Description
>SRT<	Warm start
>SRTCOLD<	Cold start
>SRTFACTORY<	Factory reset
>SRSAVE_CONFIG<	Save serial EEPROM user values

The SAVE_CONFIG data string will save parameters entered in TSIP to SEEPROM (see section A.18.11, Command Packet 0x8E-26 - SEEPROM Storage).

To save parameters to a TAIP-speaking receiver, follow these steps:

1. Change the protocol to TSIP using the TAIP PR command.
2. Enter the parameters via TSIP commands (see section 3.7).
3. Change the protocol to TAIP using TSIP command 0xBC.
4. Save to SEEPROM using the TAIP command >SRSAVE_CONFIG<.

C.20 ST Status

Data String Format:

AABCDDEFGG



Note – This message provides information about the satellite tracking status and the operational health of the sensor. This information is contained in five status bytes which are output as five 2 digit hexadecimal values. The data format and the meanings of the hex characters are given in the following tables.

Table C-19. Data String Hex Characters

Item	# of Char	Units	Format	Definition
Tracking Status Code	2	n/a	AA	(see table below)
Status Codes - Nibble 1	1	n/a	B	(see table below)
Status Codes - Nibble 2	1	n/a	C	(see table below)
Machine ID	2	n/a	DD	
Status Codes - Nibble 3	1	n/a	E	(not currently used)
Status Codes - Nibble 4	1	n/a	F	(see table below)
Reserved	2	n/a	GG	(not currently used)

Table C-20. Tracking Status Code

Value	AA Meaning
00	Doing position fixes
01	Don't have GPS time yet
02	Not used
03	PDOP is too high
08	No usable satellites
09	Only 1 usable satellite
0A	Only 2 usable satellites
0B	Only 3 usable satellites
0C	Chosen satellite is unusable

Table C-21. Error Codes: Nibble 1

Value of B	Meaning
0	No problems reported
1	Antenna feedline fault

Table C-22 Error codes: Nibble 2

Value of B	Meaning
0	No problems reported
1	Battery-backup failed; RAM not available at power-up (see Note)

Table C-23 Error Codes: Nibble 4

Value of B	Meaning
0	No problems reported
2	RTC not available at power-up (see Note)
8	Stored almanac not complete and current
A	RTC not available; stored almanac not complete and current

Note – After the status is detected, this bit remains set until the sensor is reset.

C.21 TM Time/Date

Data String Format:

AABBCCDDDEEFFGGGGHHIJKLLLLL

Table C-24. TM Time/Data Data String Descriptions

Item	# of Char	Units	Format	(Value)
Hours	2	Hour	AA	
Minutes	2	Min	BB	
Seconds	5	Sec	CC.DDD	
Date; Day	2	Day	EE	
Date; Month	2	Month	FF	
Date; Year	4	Year	GGGG	
GPS UTC Time Offset	2	Sec	HH	
Current Fix Source	1	n/a	I	0 = 2D GPS 1 = 3D GPS 2 = 2D DGPS 3 = 3D DGPS 6 = DR 8 = Degraded DR 9 = Unknown
Number of Usable SVs	2	n/a	JJ	
GPS UTC Offset Flag	1	n/a	K	(1 = Valid) (0 = Invalid)
Reserved	5	n/a	LLLLL	
Total	28			

This message outputs the time and date as computed by the GPS sensor. The time is most accurate when the unit is doing fixes. It is less accurate but still usable when the unit is not doing fixes but the Number of Usable SVs is one or more. If the GPS UTC offset is available, the time will be in UTC. If not, the time will be in GPS.



Note 1. – GPS UTC Time Offset is the difference between GPS and UTC time standards in seconds. The UTC time of Day is only valid if the GPS UTC Offset Valid Flag is indicating valid.

Note 2. – The TM message is not supported under the Set qualifier.

C.22 VR Version Number

Data String Format:

```
XXXXXXXX;VERSION A.AA(BB/BB/BB); CORE VERSION C.CC (DD/
DD/DD); E
```

Table C-25. Version Number Data String Descriptions

Item	# of Char	Units	Format
Product Name	n/a	n/a	n/a
Major Version number	4	n/a	A.AA
Major Release Date	8	n/a	BB/BB/BB

C.23 X1 Extended Status

The ACE II GPS does not support this message.

C.24 Communication Using TAIP

Communication with the unit takes place in four different ways. Message qualifiers are used to differentiate between these.

C.24.1 Query for Single Sentence

The query (Q) message qualifier is used to query the GPS sensor to respond immediately with a specific message. The format is:

```
>QAA[ ; ID=BBBB ] [ ; *CC ] <
```

where AA is the requested message identifier. Messages supported by this qualifier are AL, AP, CP, ID, IP, LN, PT, PV, RM, ST, TM, and VR.

C.24.2 Scheduled Reporting Frequency Interval

The scheduled reporting frequency interval(F) message qualifier is used to tell the unit how often and when to report a specific message. The format is:

```
>FAABBBBCCCC [ ; ID=DDDD ] [ ; *FF ] <
```

where sending this sentence tells the unit to report message specified by the two digit identifier AA at the time interval of BBBB seconds with time epoch at CCCC seconds from top of the hour. Specifying time interval of 0000 stops scheduled reporting of the message. The default is 0000 time interval for all messages except PV. The output frequency for PV at cold-start is set at once every five seconds, zero seconds from top of the hour. Messages supported by this qualifier are AL, AP, CP, ID, IP, LN, PT, PV, RM, ST, TM, and VR.



Note – The data specified by this qualifier is the timing of the message output and may be different from the time tag of the data in the message.

C.24.3 The Response to Query or Scheduled Report

The response (R) qualifier carry various types of data between the unit and the user equipment. The format is:

```
>RAA[ {B} ] [ ; ID=CCCC ] [ ; *DD ] <
```

where AA is the two character message identifier and {B} specifies the data string within the message. For the format of {B}, please refer to the message definitions in the previous section. Messages supported by the response qualifier are AL, AP, CP, ID, IP, LN, PT, PV, RM, ST, TM, and VR.

C.24.4 The Set Qualifier

The set (S) qualifier enables the user equipment to initialize/set-up various types of data in the GPS unit. The format is:

```
>SAA[ {B} ] [ ; ID=CCCC ] [ ; *DD ] <
```

where AA is the two character message identifier and {B} specifies the data string within the message. For the format of {B}, please refer to the message definitions in the previous section. Note that all the messages have very specific formats and are length dependent. Messages normally supported by the set qualifier are AL, AP, CP, DC, DD, ID, IP, LN, PT, PV, and RM.

The set qualifier may be used with the AL, CP, LN, or PV message to set more precise initial position data into the GPS sensor than can be set with the IP message.

C.24.5 Sample Communication Session

The following is a sample communication session to illustrate how message qualifiers are used. Query the sensor for version number for the TAIP firmware:

```
>QVR<
```

The sensor responds with a message in the following form:

```
>RVR OEM SK8 OEM STTP APP; VERSION 7.52 (05/23/97);*38<
```



Note – The sensor identified its product name, firmware version number, core signal processing version number, and release dates, then included the checksum for the message (the default for the CS Flag is TRUE). Also notice that the sensor did respond to our query even though we did not send a checksum.

Query the sensor for its ID number:

```
>QID<
```

The sensor will respond (assuming factory default settings):

```
>RID0000;*70<
```

Set the ID to match the number for a vehicle in your fleet and then tell the sensor to include the Vehicle ID in its responses:

```
>SID1234<
```

```
>SRM; ID_FLAG=T<
```

The ACE II GPS sensor is set by default to report the PV message once every 5 seconds. To schedule the PV message from vehicle 1234 to respond once every 10 seconds, starting at 5 seconds after the top of the hour, use the following command:

```
>FPV00100005;ID=1234<
```

The sensor will check the ID included in the message for a match with its own and then reschedule the PV message. At the next scheduled time, the sensor will respond with:

```
>RPV15714+3739438-1220384601512612;ID=1234;*7F<
```



Note – The time given in the message is the time of the last GPS fix (04:21:54 GPS), not necessarily the time of the message response. If the time of last fix is 10 or more seconds old, the age flag will be set to 1.

D GPSSK User's Guide (TAIP)

The TAIP Tool Kit, known as GPSSK is a software package available from Trimble Navigation to assist users of the Trimble ASCII Interface Protocol (TAIP). GPSSK supports all Trimble sensors that use TAIP.

GPSSK can be used to setup, diagnose, and monitor your sensor and provides the following capabilities:

- Program the GPS sensor for automatic message reporting and verify the success of the programming.
- Quickly program Vehicle ID numbers into a fleet of sensors.
- Log the GPSSK session with the GPS sensor to disk and replay the data.
- On-screen plotting of GPS positions from the sensor.
- Poll for and view combinations of TAIP messages.
- Set different polling intervals for each message type.
- Conduct an interactive terminal session with the GPS sensor.



Note – The information about GPSSK in this document is presented as a general overview. The GPSSK distribution diskette includes a READ.ME file that details the most current information about GPSSK functions and on loading and using GPSSK.

The GPSSK program does not support the TAIP messages DC and DD. These messages are used to input differential corrections to the receiver and are defined as special TAIP format versions of RTCM SC-104 Type 1 and Type 2 messages.

The GPSSK program requires well over 500K RAM. It may not run in a DOS window, and may require removal of TSRs.

D.1 The GPSSK Files

GPSSK is included on the 3.5 inch DOS formatted GPS Toolkit diskette. The diskette contains the following GPSSK related files:

- GPSSK.EXE The executable GPSSK program
- GPSSK.HLP The on-line, context-sensitive help file
- READ.ME Current information about GPSSK
- TAIP.C Sample source code for encoding and decoding TAIP

D.2 TAIP.C Source File

The sample source code for encoding and decoding TAIP messages is provided as a guide for the system integrator who is developing a communications controller that handles TAIP. There is no warranty of any kind on this software. Use it at your own risk.

The distribution diskette is not copy protected. Before using GPSSK or installing on your hard disk, make a working copy and put the original diskette in a safe place. During normal use, GPSSK will save configuration information to the diskette or current directory. Storing the original diskette away will allow you to restore the original configuration should you encounter problems.

Copy the files GPSSK.EXE and GPSSK.HLP to a hard disk directory.

D.3 GPSSK Start-up

At the DOS prompt in the directory containing GPSSK, enter the command:

```
GPSSK
```

When the program is finished loading into memory, the GPSSK title page will be displayed. The program will then wait for 10 seconds to begin normal execution; you may bypass the 10 second wait by pressing any key after the title page is displayed.

The function key menu will be displayed on the bottom of the screen. GPSSK is structured as a hierarchy of menus. The function keys control access to the menus.

To terminate GPSSK, simply back out of the menu structure by pressing [F9] until GPSSK prompts you to confirm your desire to exit the program.

At start-up, GPSSK will attempt to initialize itself by querying the sensor for some basic information. If you wish to abort the sensor initialization process and use GPSSK to replay stored data, enter [Ctrl] + [X] (hold down the control key and press x). If initialization has been aborted, you must restart GPSSK when you wish to communicate with the sensor.

D.4 On-line Help

Once GPSSK is running, on-line help is available to assist in performing all the GPSSK operations. Help is context sensitive and will display information regarding the current display or menu. A brief overview of GPSSK is available in the main menu's help screen.

There are several command line options available. For help with command line options, run GPSSK with the /HELP argument:

```
GPSSK /HELP
```

The help available on the GPSSK main menu will explain menu operation and the menu hierarchy.

D.5 Connecting the GPS Sensor

Consult the *Installation and Operator's Manual* for information on installation, power requirements and cables specific to your ACE II GPS sensor.

Connect the serial port of the sensor to the computer's COM1 or COM2 port. The default serial port settings for GPSSK are:

- 4800 baud
- 8 data bits
- 1 stop bit
- no parity

These default settings match the default settings for the ACE II GPS sensor. Consult the *Installation and Operator's Manual* for the actual default settings and type of serial port on your sensor.

If the sensor is connected to COM2, start GPSSK by entering the command:

```
GPSSK /2
```



Note – A null modem may be required when connecting the sensor to a personal computer. The serial port on your computer is a DTE port (data terminal equipment) designed to connect to a DCE port (data communications equipment). If your sensor's serial port is DTE, you must use a null modem adapter.

E NMEA 0183

NMEA 0183 is an interface protocol created by the National Marine Electronics Association. The latest release of NMEA 0183 is Version 2.1 (October 15, 1995). This protocol was originally established to allow marine navigation equipment to share information. NMEA 0183 is a simple, yet comprehensive ASCII protocol which defines both the communication interface and the data format. Since it is a well established industry standard, NMEA 0183 has also gained popularity for use in applications other than marine electronics.

For those applications requiring output only from the GPS receiver, NMEA 0183 is a popular choice since, in many cases, an NMEA 0183 software application code already exists. The ACE II GPS receiver is available with firmware that supports a subset of the NMEA 0183 messages: GGA and VTG. For a nominal fee, Trimble can offer custom firmware with a different selection of messages to meet your application requirements.

This appendix provides a brief overview of the NMEA protocol and describes both the standard and optional messages offered by the ACE II GPS.

For a complete copy of the NMEA 0183 standard, contact:

NMEA National Office
PO Box 3435
New Bern, NC 28564-3435
U.S.A.
Telephone: +1-919-638-2626
Fax: +1-919-638-4885

E.1 The NMEA 0183 Communication Interface

NMEA 0183 allows a single source (talker) to transmit serial data over a single twisted wire pair to one or more receivers (listeners). The table below lists the characteristics of the NMEA 0183 data transmissions.

Table E-1. NMEA 0183 Characteristics

Signal Characteristic	NMEA Standard
Baud Rate	4800
Data Bits	8
Parity	None (Disabled)
Stop Bits	1

E.2 NMEA 0183 Message Format

The NMEA 0183 protocol covers a broad array of navigation data. This broad array of information is separated into discrete messages which convey a specific set of information. The entire protocol encompasses over 50 messages, but only a sub-set of these messages apply to a GPS receiver like the ACE II GPS. The NMEA message structure is described below.

```
$IDMSG , D1 , D2 , D3 , D4 , . . . . . , Dn * CS [ CR ] [ LF ]
```

“\$”	The “\$” signifies the start of a message.
ID	The talker identification is a two letter mnemonic which describes the source of the navigation information. The GP identification signifies a GPS source.
MSG	The message identification is a three letter mnemonic which describes the message content and the number and order of the data fields.
“,”	Commas serve as delimiters for the data fields.
Dn	Each message contains multiple data fields (Dn) which are delimited by commas.
“*”	The asterisk serves as a checksum delimiter.
CS	The checksum field contains two ASCII characters which indicate the hexadecimal value of the checksum.
[CR][LF]	The carriage return [CR] and line feed [LF] combination terminate the message.

NMEA 0183 messages vary in length, but each message is limited to 79 characters or less. This length limitation excludes the “\$” and the [CR][LF]. The data field block, including delimiters, is limited to 74 characters or less.

E.3 NMEA 0183 Message Options

The ACE II GPS can output any or all of the messages listed in Table E-2. In its default configuration (as shipped from the factory), the ACE II outputs two messages: GGA (NMEA Version 2.1) and VTG. These messages are output at a 1 second interval with the “GP” talker ID and checksums.



Note – The user can configure a custom mix of the messages listed in Table E-2. See section 3.7 in Chapter 3, and TSIP command packets 0xBC, 0x7A, and 8E-26 in Appendix A for details on configuring NMEA output.

Warning – If too many messages are specified for output, you may need to increase the unit’s baud rate.

Table E-2. ACE II GPS NMEA Messages

Setting	Message	Description
Default	GGA	GPS fix data (NMEA Version 2.1)
	GLL	Geographic position - Latitude/Longitude
	GSA	GPS DOP and active satellites
	GSV	GPS satellites in view
	RMC	Recommended minimum specific GPS/Transit data
Default	VTG	Track made good and ground speed
	ZDA	Time & Date

The format for each message in Table E-2 is described in more detail in the next section.

E.4 NMEA 0183 Message Formats

E.4.1 GGA - GPS Fix Data

The GGA message includes time, position and fix related data for the GPS receiver.

```
$GP GGA, hhmmss, llll.lll, a, nnnnn.nnn, b, t, uu, v.v, w.w, M, x.x, M, y.y, zzzz*hh
<CR><LF>
```

Table E-3. GGA - GPS Fix Data Message Parameters

Field	Description
1	UTC of Position
2,3	Latitude, N (North) or S (South)
4,5	Longitude, E (East) or W (West)
6	GPS Quality Indicator: 0 = No GPS, 1 = GPS, 2 = DGPS
7	Number of Satellites in Use
8	Horizontal Dilution of Precision (HDOP)
9, 10	Antenna Altitude in Meters, M = Meters
11, 12	Geoidal Separation in Meters, M=Meters. Geoidal separation is the difference between the WGS-84 earth ellipsoid and mean-sea-level.
13	Age of Differential GPS Data. Time in seconds since the last Type 1 or 9 Update
14	Differential Reference Station ID (0000 to 1023)
hh	Checksum

E.4.2 GLL - Geographic Position - Latitude/Longitude

The GLL message contains the latitude and longitude of the present vessel position, the time of the position fix and the status.

```
$GP GLL,1111.111,a,YYYYY.yyy,a,hhmmss.s,A*hh<CR><LF>
```

Table E-4. GLL - Geographic Position - Latitude / Longitude Message Parameters

Field #	Description
1,2	Latitude, N (North) or S (South)
3,4	Longitude, E (East) or W (West)
5	UTC of position
6	Status: A = Valid, V= Invalid
hh	Checksum

E.4.3 GSA - GPS DOP and Active Satellites

The GSA messages indicates the GPS receiver's operating mode and lists the satellites used for navigation and the DOP values of the position solution.

```
$GP GSA,a,x,xx,xx,xx,xx,xx,xx,xx,xx,xx,xx,xx,xx,x.x,x.x,x.x*hh<CR><LF>
```

Table E-5. GSA - GPS DOP and Active Satellites Message Parameters

Field #	Description
1	Mode: M = Manual, A = Automatic. In manual mode, the receiver is forced to operate in either 2D or 3D mode. In automatic mode, the receiver is allowed to switch between 2D and 3D modes subject to the PDOP and satellite masks.
2	Current Mode: 1 = fix not available, 2 = 2D, 3 = 3D
3 to 14	PRN numbers of the satellites used in the position solution. When less than 12 satellites are used, the unused fields are null
15	Position dilution of precision (PDOP)
16	Horizontal dilution of precision (HDOP)
17	Vertical dilution of precision (VDOP)
hh	Checksum

E.4.4 GSV - GPS Satellites in View

The GSV message identifies the GPS satellites in view, including their PRN number, elevation, azimuth and SNR value. Each message contains data for four satellites. Second and third messages are sent when more than 4 satellites are in view. Fields #1 and #2 indicate the total number of messages being sent and the number of each message respectively.

```
$GP GSV,x,x,xx,xx,xx,xxx,xx,xx,xx,xxx,xx,xx,xx,xxx,xx,xx,xx,xxx,xx
*hh<CR><LF>
```

Table E-6. GSV - GPS Satellites in View Message Parameters

Field #	Description
1	Total number of GSV messages
2	Message number: 1 to 3
3	Total number of satellites in view
4	Satellite PRN number
5	Satellite elevation in degrees (90° Maximum)
6	Satellite azimuth in degrees true (000 to 359)
7	Satellite SNR (C/No), null when not tracking
8,9,10,11	PRN, elevation, azimuth and SNR for second satellite
12,13,14,15	PRN, elevation, azimuth and SNR for third satellite
16,17,18,19	PRN, elevation, azimuth and SNR for fourth satellite
hh	Checksum

E.4.5 RMC - Recommended Minimum Specific GPS/Transit Data

The RMC message contains the time, date, position, course, and speed data provided by the GPS navigation receiver. A checksum is mandatory for this message and the transmission interval may not exceed 2 seconds. All data fields must be provided unless the data is temporarily unavailable. Null fields may be used when data is temporarily unavailable.

```
$GP RMC,hhmmss.s,A,llll.lll,a,yyyyy.yyy,a,x.x,x.x,xxxxxx,x.x,a
*hh<CR><LF>
```

Table E-7. RMC - Recommended Minimum Specific GPS / Transit Data Message Parameters

Field #	Description
1	UTC of Position Fix.
2	Status: A = Valid, V = navigation receiver warning
3,4	Latitude, N (North) or S (South).
5,6	Longitude, E (East) or W (West).
7	Speed over the ground (SOG) in knots
8	Track made good in degrees true.
9	Date: dd/mm/yy
10,11	Magnetic variation in degrees, E = East / W= West
hh	Checksum (Mandatory for RMC)

E.4.6 VTG - Track Made Good and Ground Speed

The VTG message conveys the actual track made good (COG) and the speed relative to the ground (SOG).

```
$GP VTG,x.x,T,x.x,M,x.x,N,x.x,K*hh<CR><LF>
```

Table E-8. VTG - Track Made Good and Ground Speed Message Parameters

Field #	Description
1	Track made good in degrees true.
2	Track made good in degrees magnetic.
3,4	Speed over the ground (SOG) in knots.
5,6	Speed over the ground (SOG) in kilometer per hour.
hh	Checksum

E.4.7 ZDA - Time & Date

The ZDA message contains UTC, the day, the month, the year and the local time zone.

```
$GP ZDA, hhmmss.s, xx, xx, xxxx, , *hh<CR><LF>
```

Table E-9. ZDA - Time & Date Message Parameters

Field #	Description
1	UTC
2	Day (01 to 31)
3	Month (01 to 12)
4	Year
5	unused
6	unused
hh	Checksum



Note – Fields #5 and #6 are null fields in the ACE II GPS output. A GPS receiver cannot independently identify the local time zone offsets.



Caution – If UTC offset is not available, time output will be in GPS time.



Note – GPS time can be used as a timetag for the 1PPS. The ZDA message comes out 100-500 msec after the PPS.

F ACE II GPS Specifications and Mechanical Drawings

The ACE II GPS module is designed for embedded industrial computing or control, mobile computing or data collection, precision timing, and vehicle tracking applications. This appendix includes the system specifications and mechanical drawings for the ACE II GPS receiver module and the miniature magnetic mount GPS antenna.

F.1 GPS Receiver

F.1.1 General

L1 frequency (1575.42 MHz), C/A code (Standard Positioning Service), 8-channel, continuous tracking receiver, 32 correlator

F.1.2 Accuracy

Position	25 meters CEP (Circular Error Probability) (50%) without SA (Selective Availability)
Velocity	0.1 m/sec. (1 Sigma) steady state conditions (without SA)
Time	UTC to nearest microsecond with 1 pulse per second available

F.1.3 DGPS Accuracy

Position	2 meters CEP (50%)
Velocity	0.05 m/sec. (1 Sigma) steady state conditions
Time	±500 nanosecond (nominal)

F.1.4 Datum

WGS-84 (standard DMA datum set)

F.1.5 Acquisition Rate

Cold Start	<3 minutes (90%)
Warm Start	<45 seconds (90%)
Hot Start	<20 seconds (90%)

F.1.6 Dynamics

Altitude	-1000 m to +18,000 m
Velocity	515 m/sec. (maximum)
Acceleration	4g (39.2 m/sec. ²)
Jerk	20 m/sec. ³

F.2 Environmental Characteristics

F.2.1 Temperature

Receiver board:	Operating, Storage,	-40°C to +85°C 55°C to +100°C
-----------------	------------------------	----------------------------------

F.2.2 Vibration

0.008g ² /Hz	5Hz–20 Hz
0.05g ² /Hz	20Hz–100Hz
-3dB/octave	100Hz–900Hz

Specifications comply with SAE J1211 requirements

F.2.3 Altitude

-400 to +18,000 meters MSL

F.2.4 Humidity

95% R.H. non-condensing @ +60°C

F.3 Physical Characteristics

Size

Receiver board: 82.6 mm x 46.5 mm x 14.9 mm (3.25" x 1.83" x 0.587")

F.3.1 Weight

Receiver board: 28.3 g (1.0 oz) without optional shield

F.3.2 Power

Prime Power: +5 volts DC ($\pm 5\%$); 175 ma (.88 watts typical) without antenna

RAM Backup: optional +3.2 - +5.25 volts DC input via 8-pin header J3; 1 micro amp

F.4 Input/Output

F.4.1 Interface

Two TTL level, bi-directional, serial I/O ports on J3 8-pin header

F.4.2 Protocols Available

- Trimble Standard Interface Protocol (TSIP); binary data I/O provides maximum bi-directional control over all GPS board functions. Sample C source code interface routines are available.
- Trimble ASCII Interface Protocol (TAIP); ASCII message data for I/O control over a serial communication link.. Controls scheduled and polled responses from the GPS receiver. Sample C source code interface routines are available.
- NMEA 0183: Industry standard ASCII protocol for marine electronics applications. Supports NMEA sentences GGA, VTG, GLL, ZDA, and GSV, GSA, RMC.



Note – GGA and VTG are factory default messages.

F.5 Pulse Per Second

F.5.1 Timing

Under normal conditions, in the middle latitudes, the rising edge of the pulse is synchronized to UTC within 100 ns, one Sigma.

F.5.2 Pulse Width

10 microsecond wide pulse; rising edge is 20 nanoseconds or less, depending upon distributed capacitance in cable

F.5.3 Output

TTL level signal

F.5.4 Electrical

Operating Frequency: 12.504 MHz
 Crystal Frequency: 12.504 MHz, Fundamental Mode
 Tolerance ±1 ppm @ room temp
 Temperature stability: 2.5 ppm /°C

F.5.5 Environmental

Temperature: Operational -40°C to +85°C
 Storage -55°C to +105°C
 SMDevice Reflow ± 0.5 ppm max change after 240°C for 20 seconds
 Shock: ± 0.5 ppm max change after 5000G 6 msec .5 sine
 G Sensitivity: ± 0.100 5 ppm max per G
 Vibration: ± 0.5 ppm max change — 0.008g²/Hz to 20Hz
 ±0.5 ppm max change — 0.05g²/Hz to 100Hz
 -3 dB/octave — 100Hz to 900 Hz

F.5.6 Mechanical

Electrodes: Gold
 Markings on Top: 5-digit Crystal Frequency
 Manufacturer Name or Logo
 Date Code or Lot Number

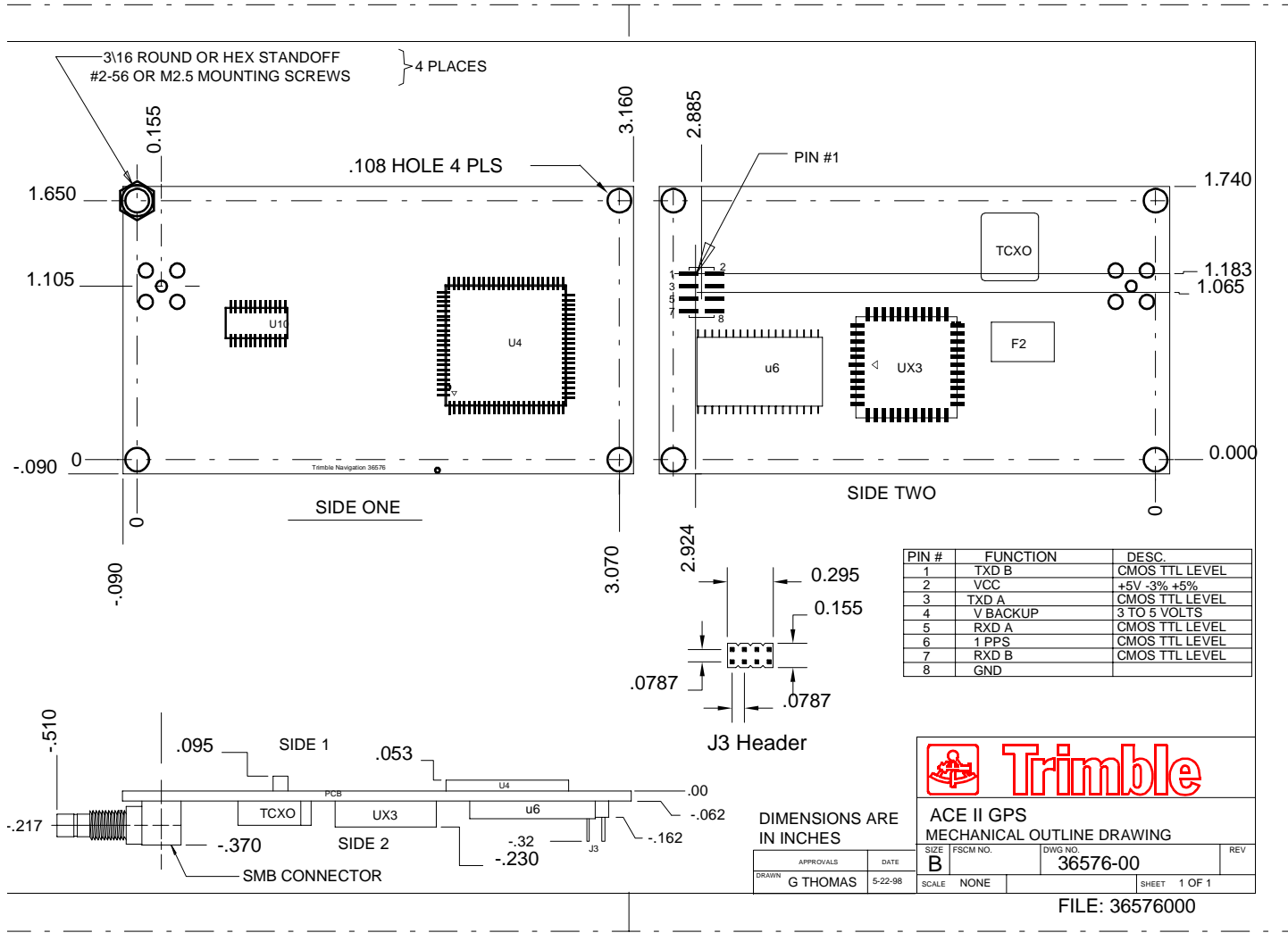

Figure F-1. ACE II GPS Circuit Board

Figure F-2. ACE II GPS Starter Kit Motherboard

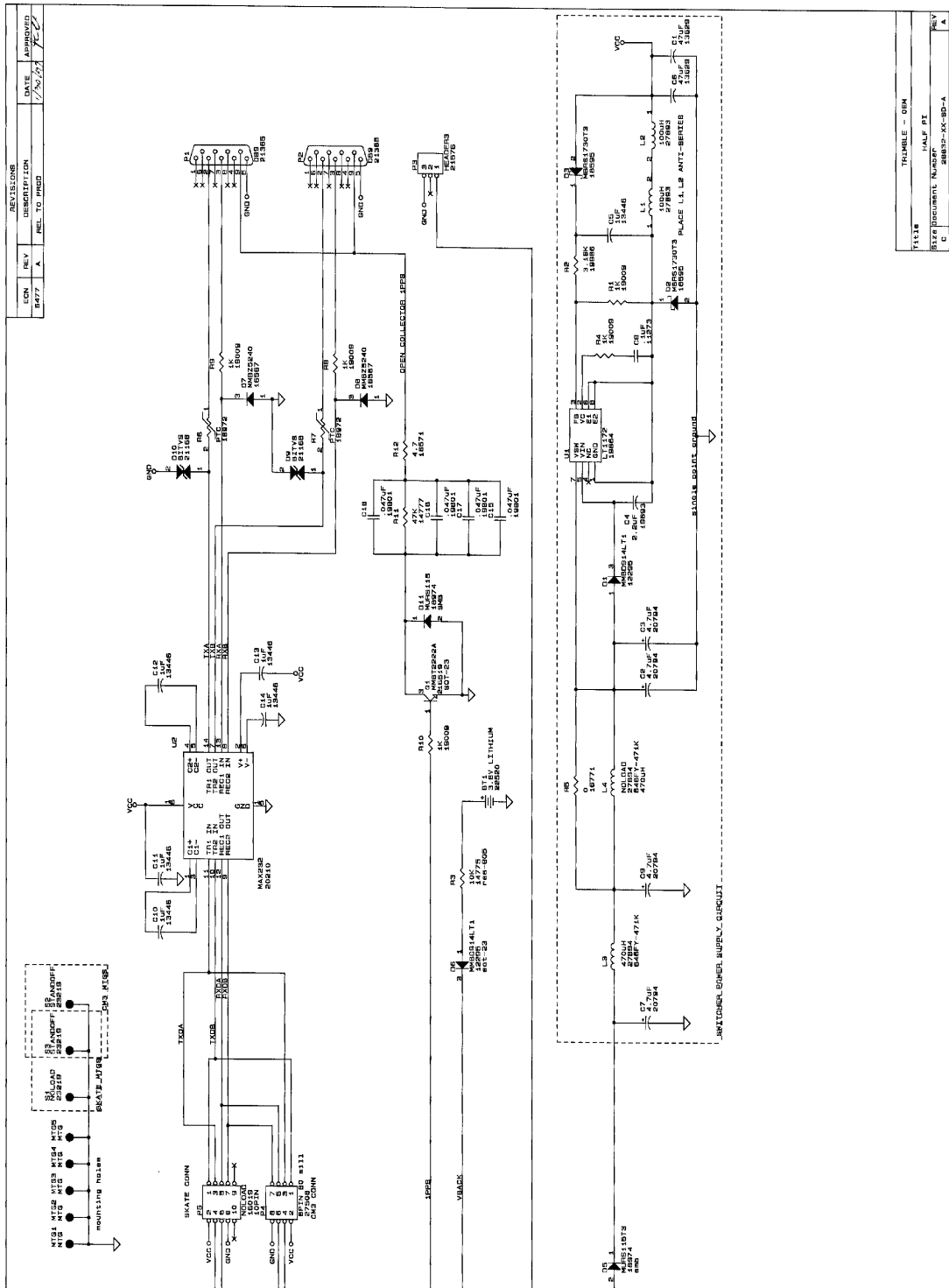

Figure F-3. Bullet II Antenna

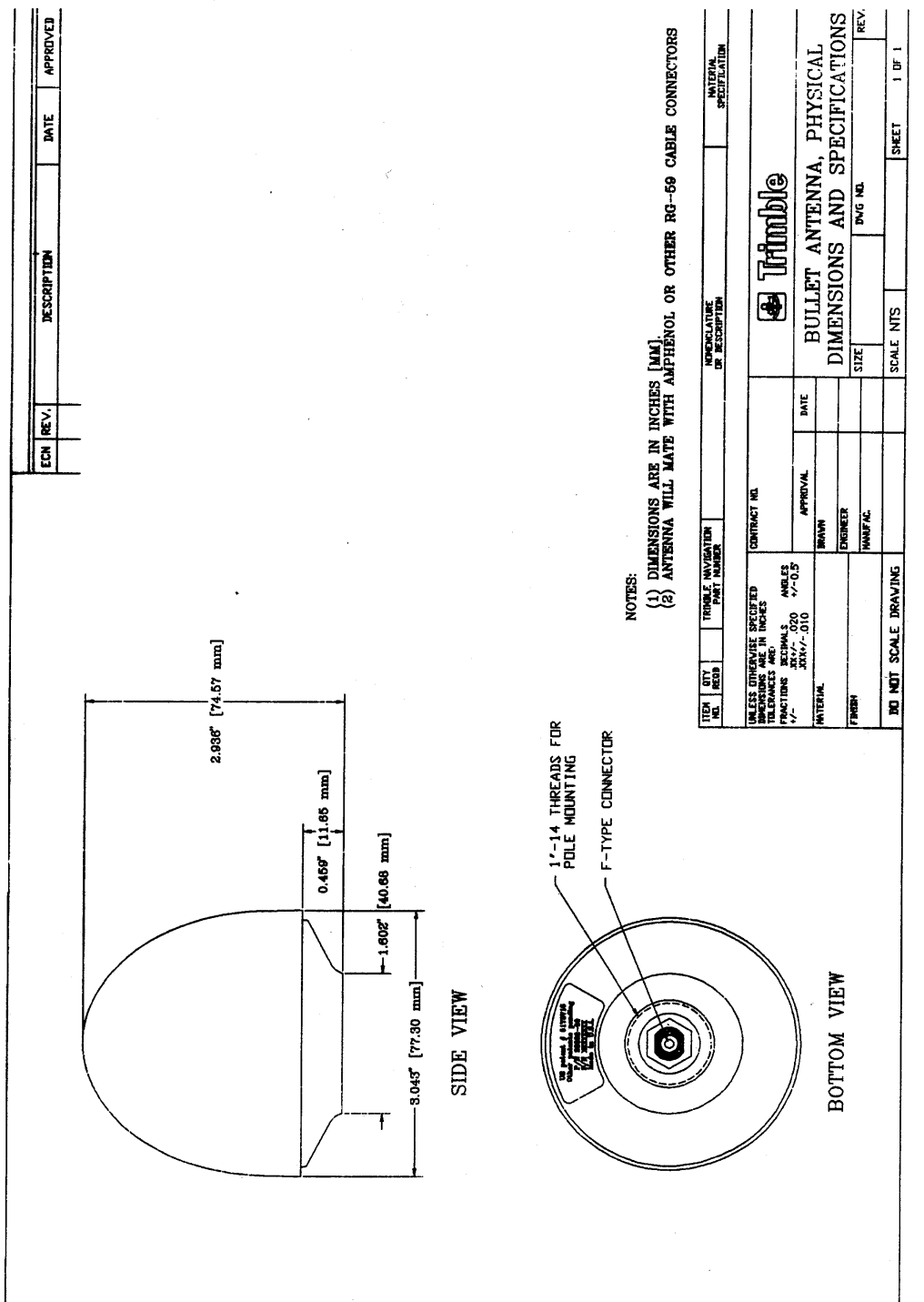

Figure F-4. Bulkhead Antenna

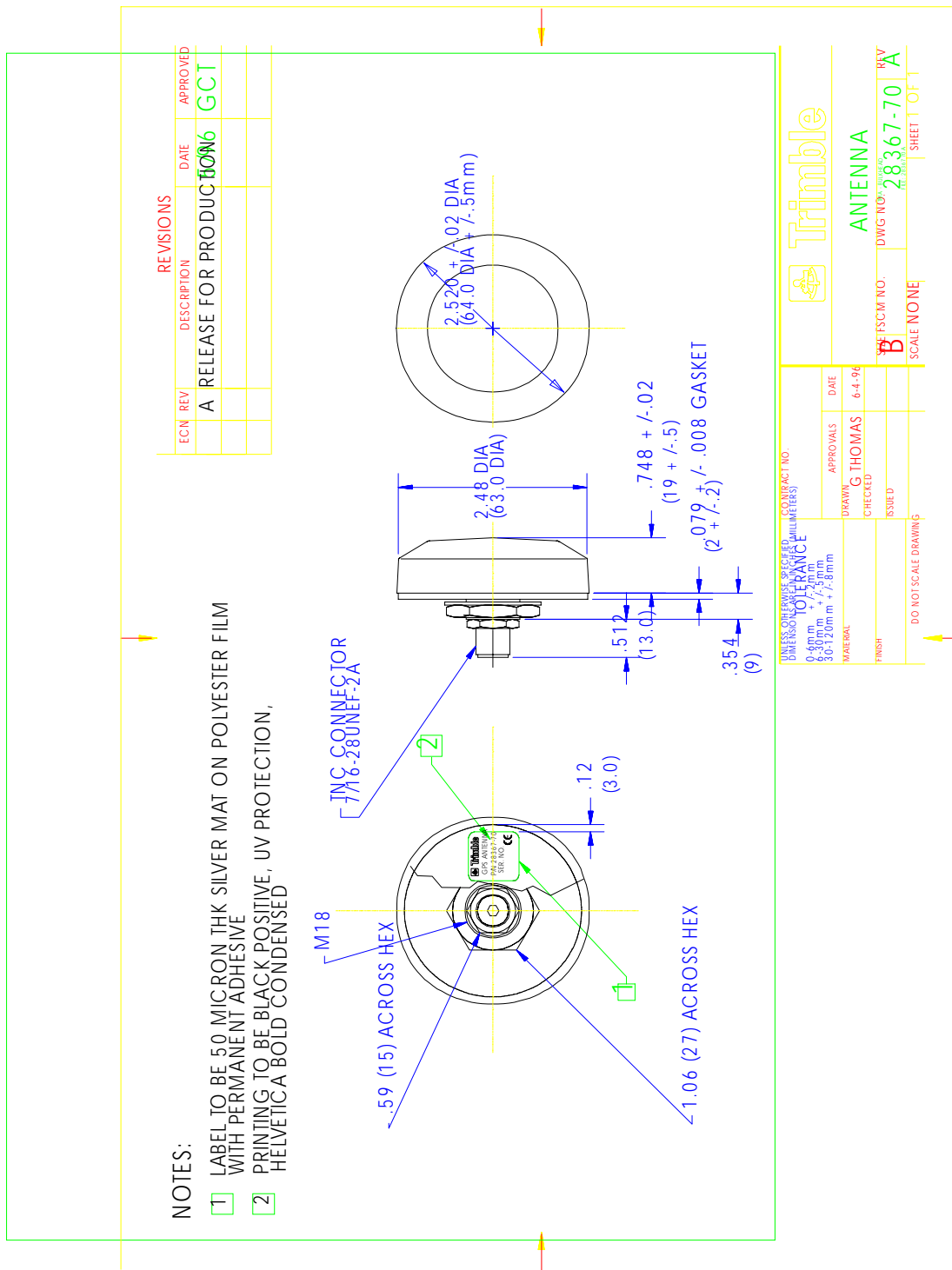
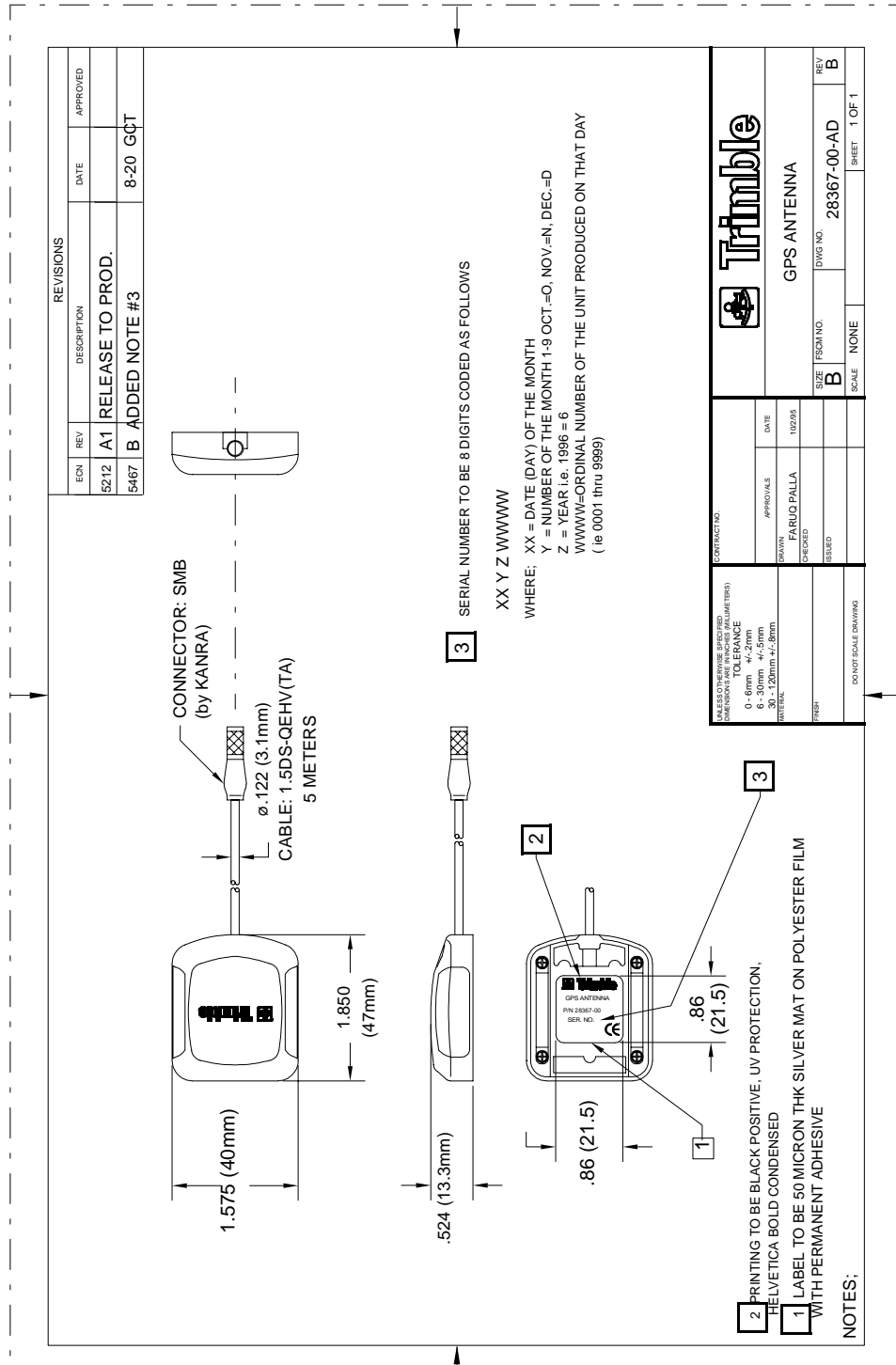

Figure F-5. GPS Miniature Antenna



Glossary

This section defines technical terms and abbreviations used in this manual. It includes terms from the field of GPS technology.

2-D GPS mode	A procedure of determining a 2-D position using signals received from the best (or only) three available GPS satellites. Altitude is assumed to be known and constant. A 2-D position solution will only be determined if signals from three or more satellites are available.
2 dRMS	Twice the distance root mean squared. The error distance within which 95% of the position solutions will fall.
3-D	Three Dimensional. A 3-D position is defined as latitude, longitude, and altitude.
2-D	Two Dimensional. A 2-D position is defined as latitude, longitude, and altitude.
3-D GPS mode	A procedure of determining a 3-D position using signals received from the best (or only) four available GPS satellites. A 3-D position solution will only be determined if signals from four or more satellites are available.
almanac	A reduced-precision subset of the ephemeris parameters. Used by the receiver to compute the elevation angle, azimuth angle, and estimated Doppler of the satellites. Each satellite broadcasts the almanac for all the satellites in the system.
ASCII	American Standard Code for Information Interchange. A standard set of 128 characters, symbols and control codes used for computer communications. ASCII characters require 7 bits of data to send, but are often sent 8 bits at a time with the extra bit being a zero.
asynchronous communication	A method of sending data in which the bits can be sent at random times. Data transmission is not synchronized to a clock. With asynchronous transmission, each character is transmitted one at a time with a “start” bit at the beginning and one or more “stop” bits at the end. Any amount of time can elapse before the next character is sent. \
auto GPS mode	A procedure of automatically determining either a 2-D or 3-D position using signals received from GPS satellites. The solution automatically transitions between 2-D and 3-D depending on the number of satellites available, the PDOP of the available satellites, and the defined PDOP switch value. (See PDOP and PDOP constellation switch).
azimuth angle	The angle of the line-of-site vector, projected on the horizontal plane, measured clockwise from true North.

bandwidth	The range of frequencies occupied by a signal. Also, the information carrying capability of a communication channel or line.
baud	A measure of the speed of data transmission. Baud and bit rate are the same for direct equipment interconnections (e.g., via RS-232). Baud and bit rate are not the same for modulated data links, whether wire or radio.
bit	Binary digit. The smallest unit of information into which digital data can be subdivided and which a computer can hold. Each bit has only two values (e.g., on/off, one/zero, true/false).
bit rate	The rate at which bits are transmitted over a communication path. Normally expressed in bits per second (bps).
byte	A set of contiguous bits that make up a discrete item of information. A byte usually consists of a series of 8 bits, and represents one character.
C/A code	The Coarse/Acquisition code. This is the civilian code made available by the Department of Defense. It is subject to selective availability (SA). Users can reduce the effects of SA by using differential GPS.
carrier	The radio signal on which information is carried. The carrier can be sensed to determine the presence of a signal.
channel	Either a single frequency or a pair of radio frequencies used as a communication path.
chip	The length of time to transmit either a zero or a one in a binary pulse code.
chip rate	Number of chips per second (e.g., C/A code = 1.023 MHz).
configuration	A set of conditions or parameters that define the structure of an item. A configuration defines the GPS processing and characteristics of the RS-232 interface ports. The term configuration can also define the hardware components that comprise a subsystem or system.
data bits	The bits in a byte of data which carry the actual information.
datum	Refers to a mathematical model of the earth. Many local datums model the earth for a small region: e.g., Tokyo datum, Alaska, NAD-27 (North America). Others, WGS-84, for example, model the whole earth.
DCE	Data Communications Equipment. The equipment that provides the functions required to establish, maintain, and terminate a communication connection. Any equipment that connects to DTE using an RS-232 or CCITT V.24 standard interface.
default setting	A preset or initial value that is assumed to be the preferred or appropriate selection for most situations. The ACE GPS sensor is shipped with factory default configuration settings; the settings were determined by Trimble Navigation.
DGPS	see <i>differential GPS</i>
DGPS reference station	A device that tracks all GPS satellites in view, periodically performs inter-channel calibrations, and calculates and transmits differential corrections.

differential capable	A term used to describe a GPS receiver that is capable of receiving and applying differential GPS corrections.
differential GPS	A procedure of correcting GPS solutions to achieve improved position accuracy. Differential GPS provides 2 to 5 meter position accuracy. Differential accuracy is obtained by applying corrections determined by the stationary Differential GPS Reference Station to the GPS data collected by the RPU unit on-board the vehicle.
differential processing	GPS measurements can be differenced between receivers, satellites, and epochs. Although many combinations are possible, the present convention for differential processing of GPS phase measurements is to take differences between receivers (single difference), then between satellites (double difference), then between measurement epochs (triple difference).
differential relative positioning	Determination of relative coordinates of two or more receivers which are simultaneously tracking the same satellites. Static differential GPS involves determining baseline vectors between pairs of receivers. Also see <i>differential GPS</i>
dilution of precision	A description of the purely geometrical contribution to the uncertainty in a position fix, given by the expression $DOP = \sqrt{\text{TRACE}(AA)}$ where AA is the design matrix for the instantaneous position solution (dependent on satellite-receiver geometry). The DOP factor depends on the parameters of the position-fix solution. Standard terms for the GPS application are: GDOP: Geometric (three position coordinates plus clock offset in the solution) PDOP: Position (three coordinates) HDOP: Horizontal (two horizontal coordinates) VDOP: Vertical (height only) TDOP: Time (clock offset only)
DOP	see <i>dilution of precision</i> .
Doppler aiding	The use of Doppler carrier-phase measurements to smooth code-phase position measurements.
Doppler shift	The apparent change in frequency of a received signal due to the rate of change of the range between the transmitter and receiver.
earth-centered earth-fixed	Cartesian coordinate system where the X direction is the intersection of the prime meridian (Greenwich) with the equator. The vectors rotate with the earth. Z is the direction of the spin axis.
elevation angle	The angle between the line of sight vector and the horizontal plane.

elevation mask angle	A measure of the minimum elevation angle, above the horizon, above which a GPS satellite must be located before the signals from the satellite will be used to compute a GPS location solution. Satellites below the elevation angle are considered unusable. The elevation mask angle is used to prevent the GPS receiver from computing position solutions using satellites which are likely to be obscured by buildings or mountains.
ellipsoid	In geodesy, unless otherwise specified, a mathematical figure formed by revolving an ellipse about its minor axis. It is often used interchangeably with spheroid. Two quantities define an ellipsoid; these are usually given as the length of the semimajor axis, a , and the flattening, $f = (a - b)/a$, where b is the length of the semiminor axis.
ephemeris	A set of parameters that describe the satellite orbit very accurately. It is used by the receiver to compute the position of the satellite. This information is broadcast by the satellites.
epoch	Measurement interval or data frequency, as in making observations every 15 seconds. Loading data using 30-second epochs means loading every other measurement.
firmware	A set of software computer/processor instructions that are permanently or semi-permanently resident in read-only memory.
frequency	The number of vibrations per second of an audio or radio signal. Measured in hertz (Hz), kilohertz (kHz), or megahertz (MHz). GPS frequencies are: L1 = 1575.42 MHz L2 = 1227.60 MHz
GDOP	Geometric Dilution of Precision. GDOP describes how much an uncertainty in pseudo-range and time affects the uncertainty in a position solution. GDOP depends on where the satellites are relative to the GPS receiver and on GPS clock offsets.
geodetic datum	A mathematical model designed to best fit part or all of the geoid. It is defined by an ellipsoid and the relationship between the ellipsoid and a point on the topographic surface established as the origin of datum. This relationship can be defined by six quantities, generally (but not necessarily) the geodetic latitude, longitude, and the height of the origin, the two components of the deflection of the vertical at the origin, and the geodetic azimuth of a line from the origin to some other point. The GPS uses WGS-84.
geoid	The actual physical shape of the earth which is hard to describe mathematically because of the local surface irregularities and sea-land variations. In geodetic terms it is the particular equipotential surface which coincides with mean sea level, and which may be imagined to extend through the continents. This surface is everywhere perpendicular to the force of gravity.
GPD	GPS with differential corrections applied.

GPS	Global Positioning System. A constellation of 24 radio navigation (not communication) satellites which transmit signals used (by GPS receivers) to determine precise location (position, velocity, and time) solutions. GPS signals are available world-wide, 24 hours a day, in all weather conditions. This system also includes 5 monitor ground stations, 1 master control ground station, and 3 upload ground stations.
GPS antenna	An antenna designed to receive GPS radio navigation signals.
GPS processor	An electronic device that interprets the GPS radio navigation signals (received by a GPS antenna) and determines a location solution. The GPS processor may also be able to apply (and determine) differential GPS corrections.
GPS receiver	The combination of a GPS antenna and a GPS processor.
GPS time	The length of the second is fixed and is determined by primary atomic frequency standards. Leap-seconds are not used, as they are in UTC. Therefore, GPS time and UTC differ by a variable whole number of seconds.
HDOP	Horizontal Dilution of Precision.
HOW	Handover word. The word in the GPS message that contains time synchronization information for the transfer from C/A to P-code.
interface cable (serial)	The interface cable allows data to flow between the ACE GPS and the communication equipment. One end of the cable has a 9-pin female RS-232 connector and the other end of this cable has a 9-pin male RS-232 connectors.
interference	Refers to the unwanted occurrences on communication channels that are a result of natural or man-made noises and signals, not properly a part of the signals being transmitted or received.
integrated Doppler	A measurement of Doppler shift frequency or phase over time.
IODE	Issue Of Data, Ephemeris. Part of the navigation data. It is the issue number of the ephemeris information. A new ephemeris is available usually on the hour. Especially important for Differential GPS operation that the IODE change is tracked at both the reference station and mobile stations.
jamming	Interference (in either transmitting or receiving signals) caused by other radio signals at exactly or approximately the same frequency
Kalman filter	A numerical method used to track a time-varying signal in the presence of noise. If the signal can be characterized by some number of parameters that vary slowly with time, then Kalman filtering can be used to tell how incoming raw measurements should be processed to best estimate those parameters as a function of time.
masks	See <i>satellite masks</i> .
maximum PDOP	A measure of the maximum Position Dilution of Precision (PDOP) that is acceptable in order for the GPS processor to determine a location solution (see PDOP).

NAVSTAR	The name given to the GPS satellites, built by Rockwell International, which is an acronym formed from NAVigation System with Time And Ranging.
NMEA	National Marine Electronics Association. An association that defines marine electronic interface standards for the purpose of serving the public interest.
NMEA 0183 message	NMEA 0183 is a standard for interfacing marine electronics navigational devices. The standard specifies the message format used to communicate with marine devices/components.
packet	An “envelope” for data, which contains addresses and error checking information as well as the data itself.
parity	A scheme for detecting certain errors in data transmission. Parity defines the condition (i.e., even or odd) of the number of items in a set (e.g., bits in a byte).
PDOP	Position Dilution of Precision. PDOP is a unitless figure of merit that describes how an uncertainty in pseudo-range affects position solutions.
PDOP constellation switch	A value, based on PDOP, that defines when the GPS receiver/processor should switch between 2-D and 3-D GPS modes. The PDOP constellation switch is only active when the GPS mode of operation is set to Auto.
PRN	Pseudo-random noise. Each GPS satellite generates its own distinctive PRN code, which is modulated onto each carrier. The PRN code serves as identification of the satellite, as a timing signal, and as a subcarrier for the navigation data.
protocol	A formal set of rules that describe a method of communication. The protocol governs the format and control of inputs and outputs.
pseudo-range	A measure of the range from the GPS antenna to a GPS satellite. Pseudo-range is obtained by multiplying the speed of light by the apparent transit time of the signal from the GPS satellite. Pseudo-range differs from actual range because the satellite and user clocks are offset from GPS time and because of propagation delays and other errors.
RAM	Random-Access Memory.
random-access memory	Memory in which information can be referred to in an arbitrary or random order. The contents of RAM are lost when the System Unit is turned off.
range	A term used to refer to the distance radio signals can travel before they must be received or repeated due to loss of signal strength, the curvature of the earth and the noise introduced because of moisture in the air surrounding the earth's surface.
range rate	The rate of change of range between the satellite and receiver. The range to a satellite changes due to satellite and observer motions. Range rate is determined by measuring the Doppler shift of the satellite beacon carrier.

read-only memory	Memory whose contents can be read, but not changed. Information is placed into ROM only once. The contents of ROM are not erased when the system unit's power is turned off.
real time clock	An electronic clock, usually battery powered, that keeps current time. Used by a GPS receiver during a warm or hot start to determine where to search for GPS satellite signals.
relative positioning	The process of determining the vector distance between two points and the coordinates of one spot relative to another. This technique yields GPS positions with greater precision than a single point positioning mode can.
rise/set time	Refers to the period during which a satellite is visible; i.e., has an elevation angle that is above the elevation mask. A satellite is said to "rise" when its elevation angle exceeds the mask and "set" when the elevation drops below the mask.
ROM	Read-Only Memory.
RS-232	A communication standard for digital data. Specifies a number of signal and control lines. RS-232 is often associated with a 25 pin connector called a DB-25.
RTCM	Radio Technical Commission for Maritime Services. Commission that recommends standards for differential GPS services. "RTCM Recommended Standards For Differential GPS Service," prepared by RTCM Special Committee No. 104 (RTCM SC-104), defines a communication protocol for sending GPS differential corrections from a differential reference station to remote GPS receivers.
satellite masks	As satellites approach the horizon, their signals can become weak and distorted, preventing the receiver from gathering accurate data. Satellite masks enable you to establish criteria for using satellite data in a position solution. There are three types of satellite masks: Elevation, SNR, and PDOP.
SA	Selective Availability. This is the name of the policy and the implementation scheme by which unauthorized users of GPS will have their accuracy limited to 100 meters 2D RMS horizontal and 156 meters 2D RMS vertical.
SEP	Spherical Error Probability. The radius of a sphere such that 50% of the position estimates will fall within the surface of the sphere.
serial communication	A system of sending bits of data on a single channel one after the other, rather than simultaneously.
serial port	A port in which each bit of information is brought in/out on a single channel. Serial ports are designed for devices that receive data one bit at a time.
signal to noise level	GPS signals with SNRs that do not meet the mask criteria are considered unusable.
signal to noise ratio	A measure of the relative power levels of a communication signal and noise on a data line. SNR is expressed in decibels (dB).

SNR	Signal to Noise Ratio.
spread spectrum	The received GPS signal is a wide bandwidth, low-power signal (-160dBW). This property results from modulating the L-band signal with a PRN code in order to spread the signal energy over a bandwidth which is much greater than the signal information bandwidth. This is done to provide the ability to receive all satellites unambiguously and to provide some resistance to noise and multipath.
SPS	Standard Positioning Service. Refers to the GPS as available to the authorized user.
start bit	In asynchronous transmission, the start bit is appended to the beginning of a character so that the bit sync and character sync can occur at the receiver equipment.
stop bit	In asynchronous transmission, the stop bit is appended to the end of each character. It sets the receiving hardware to a condition where it looks for the start bit of a new character.
SV	Space Vehicle (GPS satellite).
synchronous communication	A method of sending digital data in which the bits come at fixed, rather than random, times and are synchronized to a clock.
TAIP	Trimble ASCII Interface Protocol. Designed originally for vehicle tracking applications, TAIP uses printable uppercase ASCII characters in 16 message types for easy integration with mobile data modems, terminals, and personal computers. The TAIP protocol is defined in full in Appendix C.
TANS	Trimble Advanced Navigation Sensor. Also refers to a Trimble-specified interface protocol for digital packet communication to/from the GPS receiver. Data output includes time-tagged position and velocity, satellite status, dilution of precision factors and diagnostics of GPS receiver operational status. Also see <i>TSIP</i>
TNL 4000RL	Trimble Navigation, Ltd. Reference Locator (4000RL). Product name for the Differential GPS Reference Station.
TSIP	Trimble Standard Interface Protocol. A binary/hex packet bi-directional protocol, also known as the TANS protocol. Used by a large number of Trimble sensors. TSIP is the subset of TANS which is recognized by all Trimble sensors except the 4000 series. The TSIP protocol is defined in full in Appendix A.

URA	Satellite user range accuracy. The URA is sent by the satellite and is computed by the GPS operators. It is a statistical indicator of the contribution of the apparent clock and ephemeris prediction accuracies to the ranging accuracies obtainable with a specific satellite based on historical data.
UTC	Universal Time Coordinated. Uniform atomic time system/standard that is maintained by the US Naval Observatory. UTC defines the local solar mean time at the Greenwich Meridian.
UTC offset	The difference between local time and UTC (Example: UTC - EST = 5 hours).

